

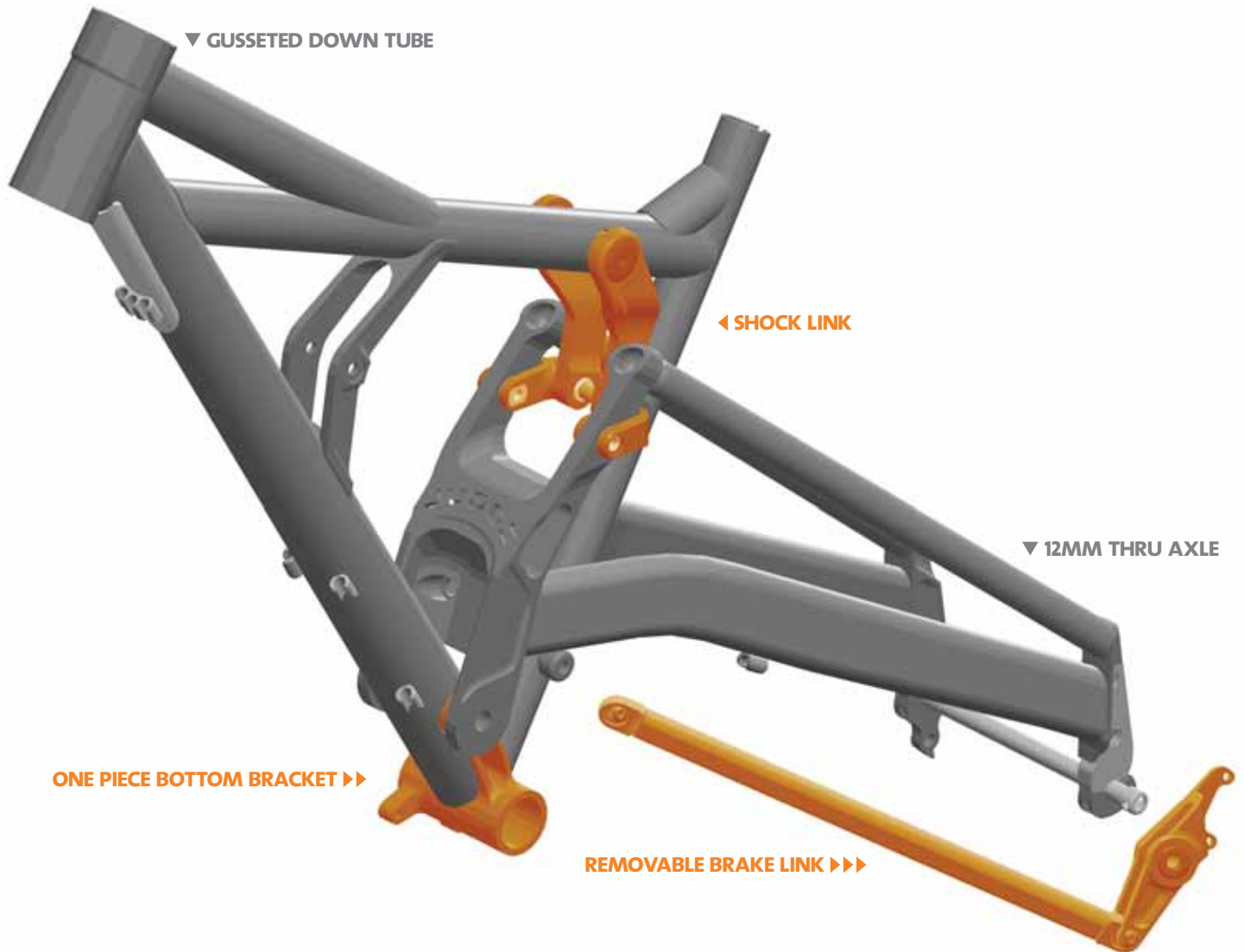

JUDGE *Perp* GEMINI

# GRAVITY

## GRAVITY



## JUDGE

► Shock link provides the staged travel necessary to turn the fast lines in to the smooth lines.

DE Die Dämpferanlenkung ermöglicht einen Riesen-Federweg mit abgestufter Kennlinie. So wird die schnellste Linie zur sanftesten Linie.

ES El conector del amortiguador trasero garantiza un recorrido por etapas que te permite trazar con suavidad las curvas más rápidas.

IT Il lincaggio dell'ammortizzatore fornisce quell'escursione graduale necessaria a trasformare le impostazioni veloci in impostazioni veloci e morbide.

FR L'étrier flottant possède un débattement étagé qui offre toute la rapidité et le confort nécessaires.

NL Schokbrekerhevel (shock link) zorgt voor gefaseerde veerweg waarbij de ideale snelle rijlijn ook de meest comfortabele wordt.

►► One piece BB / Pivot increases stiffness

DE Einteiliges Tretlager und Schwingengelenkhause zur Verbesserung der Stiefigkeit.

ES Eje de pedalier de una pieza/pivote incrementa rigidez.

IT Movimento centrale e fulcro in un unico pezzo per aumentare la rigidità.

FR Le boîtier de pédalier en une seule pièce permet d'accroître la rigidité.

NL Bracket en draaipunt uit een stuk zorgt voor meer stijfheid.

►►► Removable brake link on Judge DH is attached at the BB for added stiffness and durability, separating the braking forces from swing arm travel.

DE Abnehmbarer Bremsanker an den Judge DH: Stabile und stiefe Anlenkung am Tretlagerhause; Trennung der Bremskräfte von der Einfederung.

ES El conector flotante del freno de la Judge DH se une al eje de pedalier para incrementar la resistencia y la rigidez aislando las cargas del freno del movimiento del basculante.

IT Il lincaggio dei freni rimovibile dei modelli Judge DH è attaccato al movimento centrale per maggiore rigidità e resistenza, e permette la separazione delle forze frenanti dall'escursione del forcellone.

FR L'étrier flottant qui équipe les modèles Judge DH est fixé au tube de selle, juste au dessus du jeu de pédalier, pour offrir une rigidité et une durabilité supérieures et pour dissocier la force de freinage du débattement du bras oscillant.

NL Verwijderbare brake link op de Judge DH modellen is bevestigd aan het bracket voor meer stijfheid en duurzaamheid. Remkrachten en swingarm- beweging worden gescheiden.

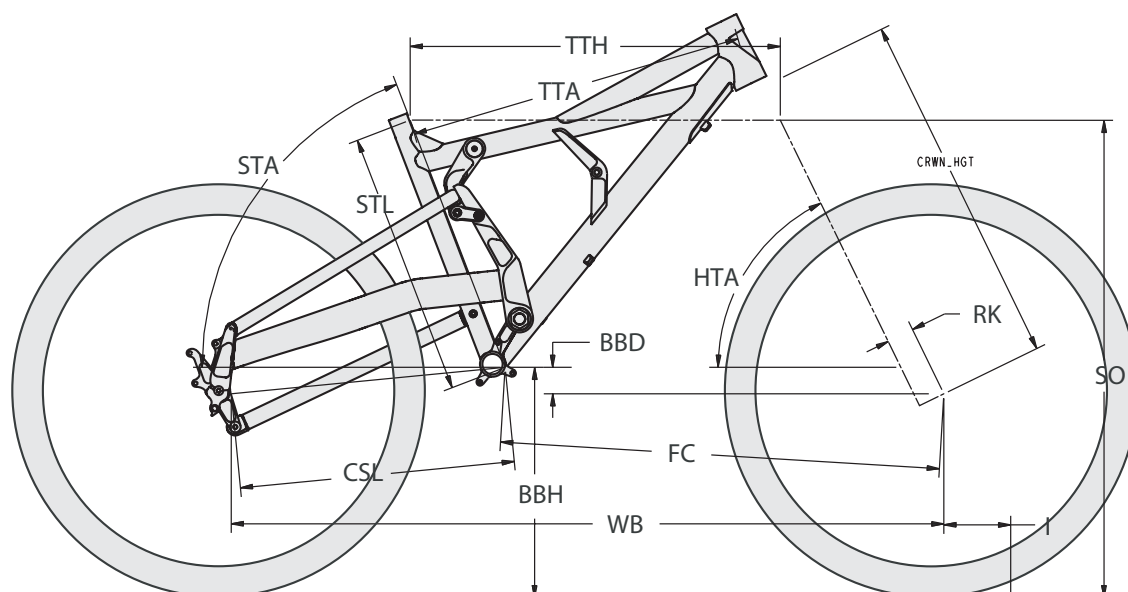

## FRAME SPECIFICATION

ITEM	SPECIFICATION	
MODEL	JUDGE	JUDGE DH
Frame material	6061 T6, TIG Welded Aluminum Alloy	
Sizes	S, M, L	
Recommended sag	30%	
Maximum tire width	76.2mm, 3.0 in	
Headtube	HEADSHOK, OnePointFive	
Headtube height	114 mm, 4.5 in	
Maximum fork length	610mm	
Seatpost diameter	27.2mm	
Rear shock mounting	FRONT: 8.1 ± 0.05mm	
Bolt hole diameter	REAR: 10.0 ± 0.05mm	
Rear shock front bushing width	32.4 ± 0.1mm	
Rear shock rear bushing width	17.4 ± 0.1mm	
Rear shock eye-to-eye length	241mm, 9.5 in	
Rear wheel travel	220mm, 8.7 in	
Rear shock stroke length	76mm, 3.0 in	
Rear shock leverage ratio	3.5:1 to 2.5:1 Progressive, 2.89:1 Average	
Front derailleur	31.8 Bottom Pull Top Swing	
Bottom bracket shell width	83mm	
Bottom bracket shell thread type	English	
Chain line	56mm	
Dropout spacing*	150mm	
Rear hub spacing	150mm	135mm
Rear hub axle	Thru12 150mm	Thru 12 165mm
Rear brake mount	International Standard 6" or 8" rotor compatible	
Chain retention system**	International Standard Chain Guide 2005 (ISCG05)	

\* The 150 mm swing arm dropout spacing uses a 135mm, 12mm axle hub and 15mm brake carrier - (135 mm + 15 mm = 150 mm drop out spacing).

\*\* The bottom bracket design is compatible with chain retention devices conforming to the International Standard Chain Guide 05 (ISCG 05). However, due to variances in design within the ISCG 05 standard and component quality, some "compatible" devices may fit and work better than others. For that reason, we recommend that you run the rear suspension through its complete range of travel when checking the device for interference. As always, it's a great idea to consult with your Cannondale Dealer about compatibility before deciding on any component for your bike.

## GEOMETRY

ITEM	REF	SMALL	MEDIUM	LARGE
Seat tube angle (degree)	STA	69	69	69
Head tube angle (degree)	HTA	64	64	64
Horizontal top tube (cm)	TTH	57.5	59.5	61.5
Horizontal top tube actual (cm)	TTA	51.8	53.9	56.1
Seat tube length (cm)	STL	40.5	42.5	44
Chainstay length (cm)	CSL	45.7	45.7	45.7
Bottom bracket height (cm)	BBH	37.4	37.4	37.4
Wheelbase (cm)	WB	114.1	116.3	118.4
Head tube height (cm)		59	59	59
Stand over height (cm)	SO	77.9	78.2	78.5
Bottom bracket drop (cm)	BBD	4.4	4.4	4.4
Front-center distance (cm)	FC	68.7	70.9	73.1
Maximum fork length (cm)		61	61	61
Fork rake (cm)	RK	4.5	4.5	4.5
Rear travel (cm)		22	22	22
Shock eye-to-eye (cm)		24.1	24.1	24.1
Shock stroke (cm)		7.6	7.6	7.6
Recommended sag (%)		30	30	30

\* All dimensions: suspension fully extended.

## GRAVITY



## JUDGE DH

Frame	▽	Judge 220mm
Fork	┌	RockShox Boxxer Wold Cup 200mm Thru-20
Rear Shock	⊞	Fox DHX 5.0 Coil
Rims	○	N/A
Hubs	⊞	N/A
Spokes	✱	N/A
Tires	▨	N/A
Pedals	⊞	N/A
Crank	⊞	N/A
Bottom Bracket	⊞	N/A
Chain	○	N/A
Rear Cogs	≡	N/A
Front Derailleur	≡	N/A
Rear Derailleur	≡	N/A
Shifters	⊞	N/A
Handlebar	┌	N/A
Stem	⊞	N/A
Headset	⊞	FSA Orbit Z 1-1/8"
Brakes	⊞	N/A
Brake Levers	┌	N/A
Saddle	┌	Fi'zi:k FREEK
Seatpost	┌	FSA SP-DH-300, 27.2 x 350mm
Sizes	≡	S,M,L
Color Code	⊞	Cut Team Replica (gloss) (REP)
Extra's	⋮	N/A

Notes:



## JUDGE FR

Frame	∇	Judge 220mm
Fork	∩	Marzocchi 888 VF 200mm Thru-20
Rear Shock	⊞	Marzocchi Roco C/R Coil
Rims	○	N/A
Hubs	⊞	DT Swiss Hugi Thru-20 front, Thru-12 rear
Spokes	✱	N/A
Tires	⋯	N/A
Pedals	⊞	N/A
Crank	⊞	N/A
Bottom Bracket	⊞	N/A
Chain	○	N/A
Rear Cogs	⊞	N/A
Front Derailleur	⊞	N/A
Rear Derailleur	⊞	N/A
Shifters	⊞	N/A
Handlebar	∩	N/A
Stem	⊞	N/A
Headset	⊞	FSA Orbit Z 1-1/8"
Brakes	⊞	N/A
Brake Levers	∩	N/A
Saddle	∩	Fi'zi:k FREEK
Seatpost	∩	FSA SP-DH-300, 27.2 x 350mm
Sizes	⊞	S,M,L
Color Code	∩	Jet Black (matte) (BBQ)
Extra's	...!	N/A

Notes:

## GRAVITY

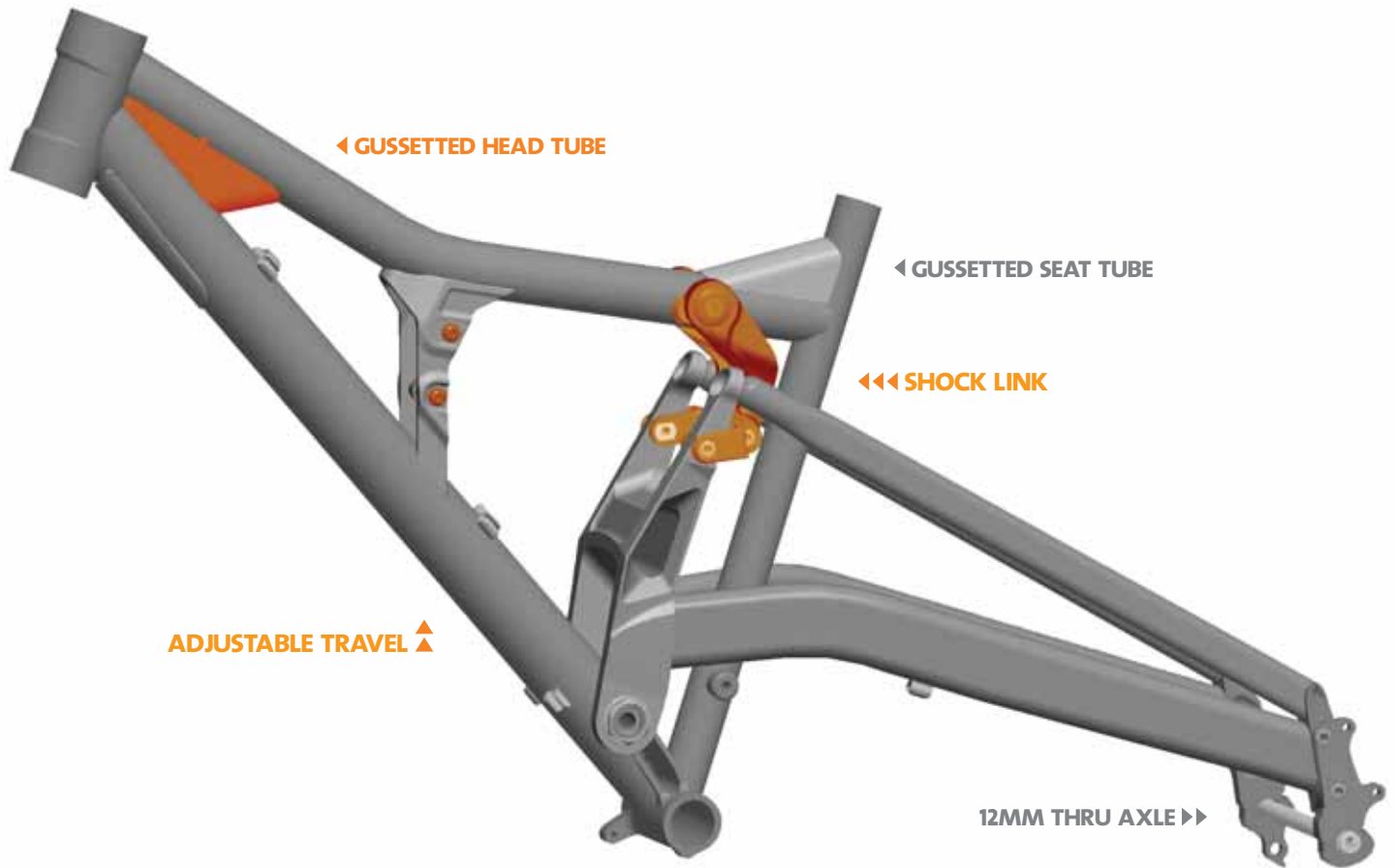

## PERP

► Built, then overbuilt. The massive, gussetted headtube area is designed to withstand big drops.

DE Erbaut, dann verstärkt. - Das massive Steuerrohr ist durch ein Gusset verstärkt und hält auch großen Drops stand.

ES Construcción a prueba de bombas. Pipa reforzada para soportar los grandes impactos.

IT Costruita, e poi ricostruita. La massiccia e rinforzata zona del tubo sterzo è stata creata per resistere ai grandi salti.

FR Dimensionné puis surdimensionné. Le tube de direction, massif et à goussets, est conçu pour résister aux chocs les plus violents.

NL Bouwen, en dan versterken. De massieve, versterkte stuurbuis is ontworpen om grote klappen te weerstaan.

►► THE freeride frame, with 180/200mm of adjustable travel for the perfect (free) ride.

DE DER Freeride-Rahmen, mit zwischen 180 und 200 mm wählbarem Federweg. Die Basis für den perfekten (Free-)Ride.

ES El cuadro de freeride perfecto con 180 o 200 mm de recorrido ajustable.

IT IL telaio freeride, con 180/200mm di escursione regolabile per un perfetto freeride.

FR C'est LE cadre Freeride, avec un débattement ajustable de 180/200 mm, pour du freeride parfait.

NL HET freeride-frame met 180/200mm instelbare veerweg voor de perfecte (free) ride.

►►► Optimized, the Shock link provides staged and adjustable travel for differing conditions

DE Der optimierte Federbeinlenkhebel ermöglicht eine gestufte Federkennlinie und einen einstellbaren Federweg. Ideal für wechselnde Geländebedingungen.

ES El conector del amortiguador proporciona un recorrido en etapas que se adapta a todas las condiciones.

IT Ottimizzato, il lincaggio dell'ammortizzatore fornisce un'escursione graduale e regolabile per le diverse condizioni.

FR L'étrier flottant optimisé offre un débattement étagé et réglable pour s'adapter aux conditions et au terrain.

NL Geoptimaliseerd, de Shock link-hevel zorgt voor gefaseerde en instelbare veerweg voor wisselende omstandigheden.

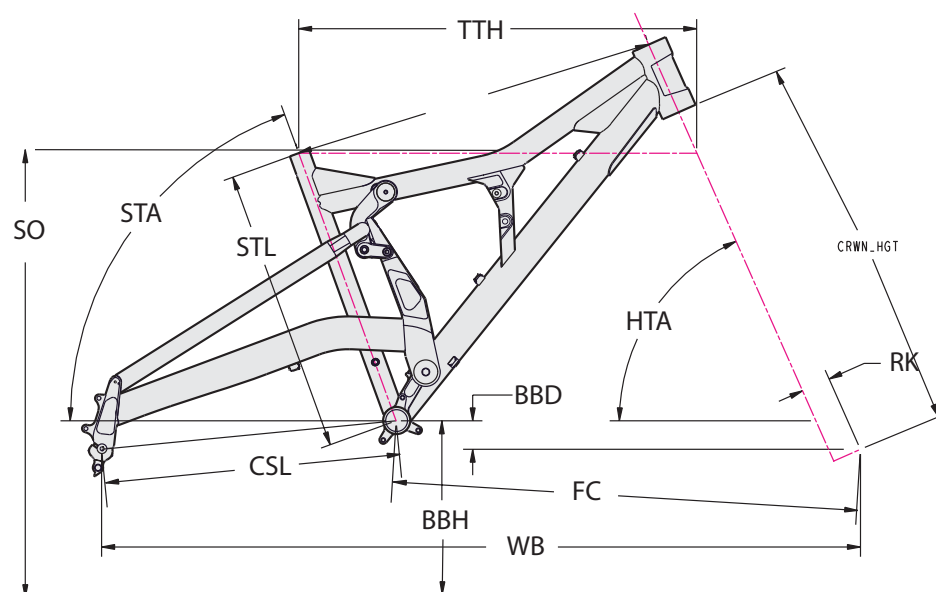

## FRAME SPECIFICATION

ITEM	SPECIFICATION
MODEL	PERP
Frame material	6061 T6, TIG Welded Aluminum Alloy
Sizes	S, M, L, X
Recommended sag	30%
Maximum tire width	76.2mm, 3.0 in
Headtube	HEADSHOK, OnePointFive
Headtube height	114 mm, 4.5 in
Seatpost diameter	27.2mm
Front derailleur	31.8 Bottom Pull Top Swing
Bottom bracket shell width	83mm
Bottom bracket shell thread type	English
Chain line	56mm
Dropout spacing	150mm
Rear hub spacing	150mm
Rear hub axle	Thru12 150mm
Rear brake mount	International Standard 6" or 8" rotor compatible
Chain retention system*	International Standard Chain Guide 2005 (ISCG05)

\* The bottom bracket design is compatible with chain retention devices conforming to the International Standard Chain Guide 05 (ISCG 05). However, due to variances in design within the ISCG 05 standard and component quality, some "compatible" devices may fit and work better than others. For that reason, we recommend that you run the rear suspension through its complete range of travel when checking the device for interference. As always, it's a great idea to consult with your Cannondale Dealer about compatibility before deciding on any component for your bike.

## GEOMETRY

ITEM	REF	SMALL	MEDIUM	LARGE	X-LARGE
Seat tube angle (degree)	STL	71	70	70	70
Head tube angle (degree)	HTA	66	66	66	66
Horizontal top tube (cm)	TTH	57.5	59.5	61.5	63.5
Horizontal top tube actual (cm)	TTA	52.6	54.5	56.6	58.5
Seat tube length (cm)	STL	40.5	42.5	44	44
Chainstay length (cm)	CSL	45.7	45.7	45.7	45.7
Bottom bracket height (cm)	BBH	37.4	37.4	37.4	37.4
Bottom bracket drop	BBD	4.4	4.4	4.4	4.4
Wheelbase (cm)	WB	113.8	115.1	117.3	119.3
Stand over height (cm)	SO	78.5	78.6	78.8	79
Front-center distance (cm)	FC	68.4	69.8	71.9	73.9
Head tube height (cm)	HTH	59	59	59	59
Fork rake (cm)	RK	4.5	4.5	4.5	4.5
Fork trail (cm)	TR	9.8	9.8	9.8	9.8
Rear travel 200 mm pos. (cm)		20.3	20.3	20.3	20.3
Rear travel 180 mm pos. (cm)		18.3	18.3	18.3	18.3
Shock eye-to-eye (cm)		22.23	22.23	22.23	22.23
Shock stroke (cm)		6.99	6.99	6.99	6.99
Recommended sag (%)		30	30	30	30



**PERP 1**

Frame	▽	Perp 180-200mm
Fork	┌	RockShox Totem Coil 180mm w/Maxle
Rear Shock	⊞	Fox Van R Coil
Rims	○	Mavic EX729 Disc, 36 hole
Hubs	⊞	Sun Ringle Abbah Thru-20 front, Thru-12 rear
Spokes	✱	DT Swiss Champion
Tires	⋯	Maxxis High Roller, 26 x 2.5"
Pedals	⊞	Cannondale Grind Platform
Crank	⊞	TruVatiV Hussefelt, 24/36/PC guard
Bottom Bracket	⊞	TruVatiV Howitzer
Chain	○	Shimano HG-73
Rear Cogs	≡	SRAM PG-950, 11-34
Front Derailleur	≡	Shimano LX
Rear Derailleur	≡	SRAM X-9 medium cage
Shifters	⊞	SRAM X-9 Trigger
Handlebar	┌	FSA FR-330 BOS, 40mm rise
Stem	┌	Cannondale Freeride 1.5" 31.8mm
Headset	⊞	FSA Orbit Xtreme Pro 1.5"
Brakes	⊞	Magura Louise BAT w/ 203mm rotors
Brake Levers	┌	Magura Louise BAT
Saddle	┌	SDG BelAir ST
Seatpost	┌	SDG I-Beam, 27.2 x 350mm
Sizes	≡	S,M,L
Color Code	┌	Galvanized (gloss) (GZD)
Extra's	⋯	Cannondale Grind grips
Notes:		



## PERP 2

Frame	▽	Perp 180-200mm
Fork	┆	RockShox Domain 318 Coil 160-180mm w/Maxle
Rear Shock	▢	Fox Van R Coil
Rims	○	Mavic EX325, 32 hole
Hubs	⊕	Formula DC-91 front, DC-91 rear
Spokes	✱	DT Swiss Champion
Tires	⋯	Maxxis High Roller, 26 x 2.5"
Pedals	⊞	Cannondale Grind Platform
Crank	⊙	TruVatiV Ruktion, 24/36/PC guard
Bottom Bracket	⊞	TruVatiV Howitzer
Chain	○	Shimano HG-53
Rear Cogs	⊞	SRAM PG-950, 11-34
Front Derailleur	⊞	Shimano LX
Rear Derailleur	⊞	SRAM X-9 medium cage
Shifters	⊞	SRAM X-7 Trigger
Handlebar	┆	FSA FR-330 BOS, 40mm rise
Stem	┆	Cannondale Freeride 1.5" 31.8mm
Headset	⊞	FSA Orbit Xtreme Pro 1.5"
Brakes	⊞	Hayes HFX 9 w/ 8" rotors
Brake Levers	┆	Hayes HFX 9
Saddle	┆	WTB Laser Pro V
Seatpost	┆	Cannondale C4, 27.2 x 350mm
Sizes	┆	S,M,L
Color Code	┆	Teak Brown (matte) (BRN)
Extra's	...!	Cannondale Grind grips

Notes:

## GRAVITY

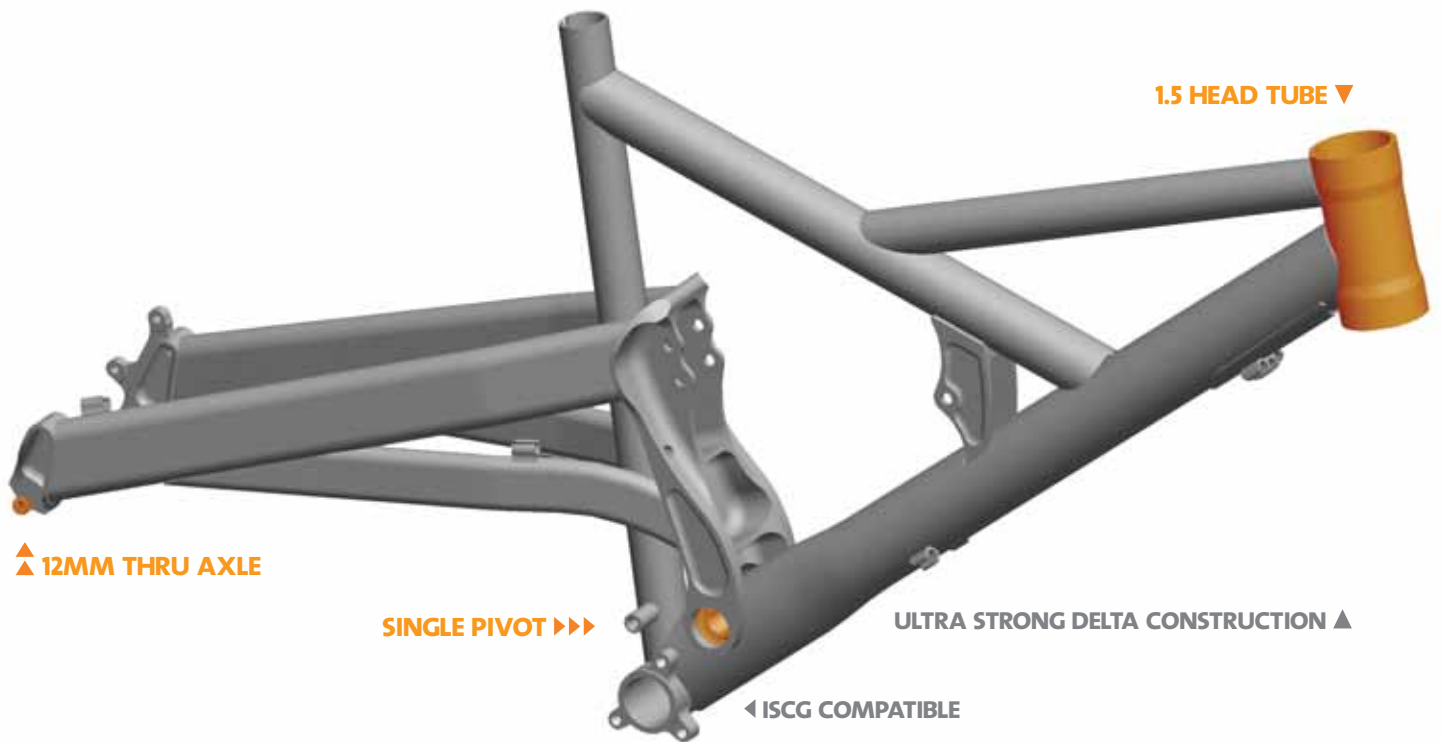

1.5 HEAD TUBE ▼

▲ 12MM THRU AXLE

SINGLE PIVOT ►►

ULTRA STRONG DELTA CONSTRUCTION ▲

◀ ISCG COMPATIBLE

## GEMINI

### ► 1.5 Headtube for greater strength and broader fork compatibility.

- DE 1,5-Zoll-Steuerrohr. Stabiler, maximale Freiheit bei der Gabelwahl.
- ES Más resistencia y mayor compatibilidad gracias a la dirección de una pulgada y media.
- IT Tubo sterzo OnepointFive (38,1 mm) per maggiore robustezza e più ampia compatibilità per la forcella.
- FR Tube de direction de 1,5 pouces (38,1 mm) pour une solidité accrue et une plus grande liberté dans le choix de la fourche.
- NL 1.5 inch stuurbuis is sterker en geeft meer toepassingsmogelijkheden voor andere vorken.

### ►► 12mm thru axle increases rear end stiffness, for a more predictable ride.

- DE Höhere Hinterbauteifigkeit und präzise Spurhaltung durch 12-Millimeter-Steckachse.
- ES El eje pasante de 12 mm mejora la rigidez trasera para permitir un mejor control.
- IT Il perno passante di 12mm incrementa la rigidità della parte posteriore per una corsa più affidabile.
- FR L'axe de 12 mm permet d'augmenter la rigidité de la partie arrière et d'offrir une meilleure stabilité.
- NL 12mm thru axle steekas verhoogt de stijfheid in de achtertrein voor een meer voorspelbaar rijgedrag.

### ►►► Single pivot design provides 150/170mm of adjustable travel along with easy maintenance.

- DE Die Eingelenkskonstruktion bietet einen Federweg von 150 bzw. 170 mm bei minimalem Wartungsaufwand.
- ES Diseño de pivote único: recorrido ajustable (150-170 mm) y fácil mantenimiento.
- IT Il design a fulcro singolo fornisce 150/170 mm di escursione regolabile e richiede una semplice manutenzione.
- FR La conception à pivot unique permet un débattement ajustable de 150 à 170 mm et un entretien facilité.
- NL Ontwerp met enkel draaipunt combineert 150/170mm instelbare veerweg met eenvoudig onderhoud.

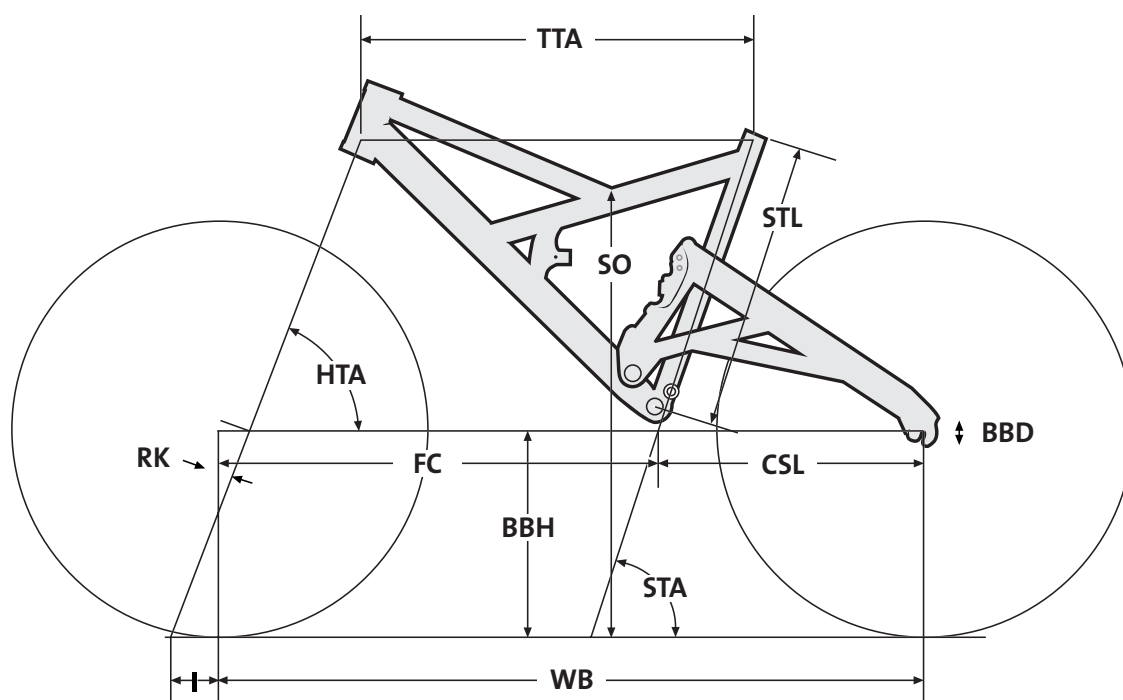

## FRAME SPECIFICATION

## GEOMETRY

ITEM	SPECIFICATION
MODEL	Gemini
Frame material	6061 T6, TIG Welded Aluminum Alloy
Sizes	S, M, L, X
Recommended sag	30%
Maximum tire width	76.2mm, 3.0 in
Headtube	HEADSHOK, OnePointFive
Headtube height	114 mm
Maximum fork length	570mm
Seatpost diameter	27.2mm
Rear shock mounting bolt diameter	FRONT: 8.5 ± 0.05mm
Rear shock front bushing width	27.4 ± 0.1mm
Rear shock rear bushing width	32.4 ± 0.1mm
Rear shock eye-to-eye length	200mm
Rear wheel travel	150mm
Rear shock stroke length	57mm
Rear shock leverage ratio	2.6:1@150mm
Front derailleur	E-Type
Bottom bracket shell width	68mm
Bottom bracket shell thread type	English
Chain line	47.5mm
Dropout spacing*	135mm
Rear hub spacing	135mm
Rear hub axle	Thru12
Rear brake mount	International Standard 6" or 8" rotor compatible
Chain retention system**	International Standard Chain Guide 2005 (ISCG05)

\* The bottom bracket design is compatible with chain retention devices conforming to the International Standard Chain Guide 05 (ISCG 05). However, due to variances in design within the ISCG 05 standard and component quality, some "compatible" devices may fit and work better than others. For that reason, we recommend that you run the rear suspension through its complete range of travel when checking the device for interference. As always, it's a great idea to consult with your Cannondale Dealer about compatibility before deciding on any component for your bike.

ITEM	REF	SMALL	MEDIUM	LARGE
Seat tube angle (degree)	STA	67.5	67.5	67.5
Head tube angle (degree)	HTA	66	66	66
Horizontal top tube (cm)	TTH	58.5	61	63.5
Horizontal top tube actual (cm)	TTA	53.5	56.3	59.3
Seat tube length (cm)	STL	40.5	45	48
Chainstay length (cm)	CSL	45.4	45.4	45.4
Bottom bracket height (cm)	BBH	37.5	37.5	37.5
Wheelbase (cm)	WB	110.8	110.8	110.8
Stand over height (cm)	SO	76.5	77	77
Bottom bracket drop (cm)	BBD	-3.2/-1.3	-3.2/-1.3	-3.2/-1.3
Front-center distance (cm)	FC	65.5	68.2	70.8
Fork crown height (cm)		55.9	55.9	55.9
Fork rake (cm)	RK	4	4	4
Trail	TR	10.9	10.9	10.9
Rear travel (cm)		18	18	18
Shock eye-to-eye (cm)		24.1	24.1	24.1
Shock stroke (cm)		7.6	7.6	7.6
Recommended sag (%)		30	30	30

\* All dimensions: suspension fully extended.

## GRAVITY



## GEMINI

Frame	▽	Gemini 150-170 mm
Fork	∩	Marzocchi Drop Off Triple 170mm Thru-20
Rear Shock	⊞	Fox Vanilla R Coil
Rims	○	Sun Ditch Witch, 32 hole
Hubs	⊞	Formula DC-91 front, DC-36 rear
Spokes	✱	DT Swiss Champion
Tires	⋯	Maxxis ADvantage, 26 X 2.4"
Pedals	⊞	Cannondale Grind Platform
Crank	⊞	TruVatiV Ruktion, 24/36/PC guard
Bottom Bracket	⊞	TruVatiV Howitzer
Chain	○	Shimano HG-53
Rear Cogs	≡	SRAM PG-950, 11-34
Front Derailleur	↗	Shimano Alivio
Rear Derailleur	↘	SRAM X-7 medium cage
Shifters	⊞	SRAM SX-5 Trigger
Handlebar	∩	FSA FR-330 BOS, 40mm rise
Stem	⊞	Cannondale Freeride 1 1/8" 31.8mm
Headset	⊞	FSA Orbit Z 1-1/8"
Brakes	⊞	Avid Juicy 3 w/ 185mm rotors
Brake Levers	∩	Avid Juicy 3
Saddle	∩	VELO 2051 FR
Seatpost	∩	Cannondale C4, 27.2 x 350mm
Sizes	≡	S,M,L,X
Color Code	∩	Raw Hi-Bright Aluminum (matte) (RAW)
Extra's	⋯!	Cannondale Grind grips

Notes:



CHASE

# STREET/DIRT JUMP

## STREET/DIRT JUMP



### THE BEST 26" JUMP BIKE

## CHASE

#### ► CNC'd yoke is strong, flex free and provides acres of tire clearance.

- DE Die CNC-bearbeitete Kettenstrebenverbindung ist extrem stabil, verwindet sich nicht und ermöglicht dennoch maximalen Reifendurchlass.
- ES La unión de vainas mecanizada, indestructible y rígida, se sitúa a una amplia distancia del neumático.
- IT Lo yoke lavorato a macchina CNC è robusto, rigido e fornisce uno spazio libero molto ampio per le gomme.
- FR Le yoke usiné sur machine à commande numérique est très résistant, rigide et offre un dégagement de pneu généreux.
- NL Het CNC-gefreesde verbindingstuk is sterk, buigt niet en verschaft ruim voldoende bandenvrijheid.

#### ►► ISCG compatible

- DE ISCG-kompatibel.
- ES Compatible con sistemas de retención de la cadena ISCG.
- IT Compatibile ISCG.
- FR Compatible ISCG.
- NL ISCG compatibel.

#### ►►► Our World class engineers and world class riders got together and made the best 26" jump bike available today.

- DE Nachdem sich unsere Weltklasse-Ingenieure und Weltklasse-Fahrer zusammengesetzt hatten, kam das beste 26-Zoll-Jump-Bike heraus, das heute erhältlich ist.
- ES Nuestros ingenieros y atletas de elite han colaborado para crear la mejor bicicleta para campillo de 26 pulgadas del mercado.
- IT I nostri ingegneri ed i nostri atleti di altissimo livello si sono messi insieme ed hanno creato le migliori dirt bike da 26 pollici disponibili sul mercato.
- FR Nos ingénieurs et nos champions de renommée mondiale se sont associés pour produire le meilleur vélo de dirt existant à ce jour.
- NL Onze ingenieurs en rijders van wereldklasse zijn samengekomen en hebben de beste 26" jump bike gebouwd die op dit moment verkrijgbaar is.

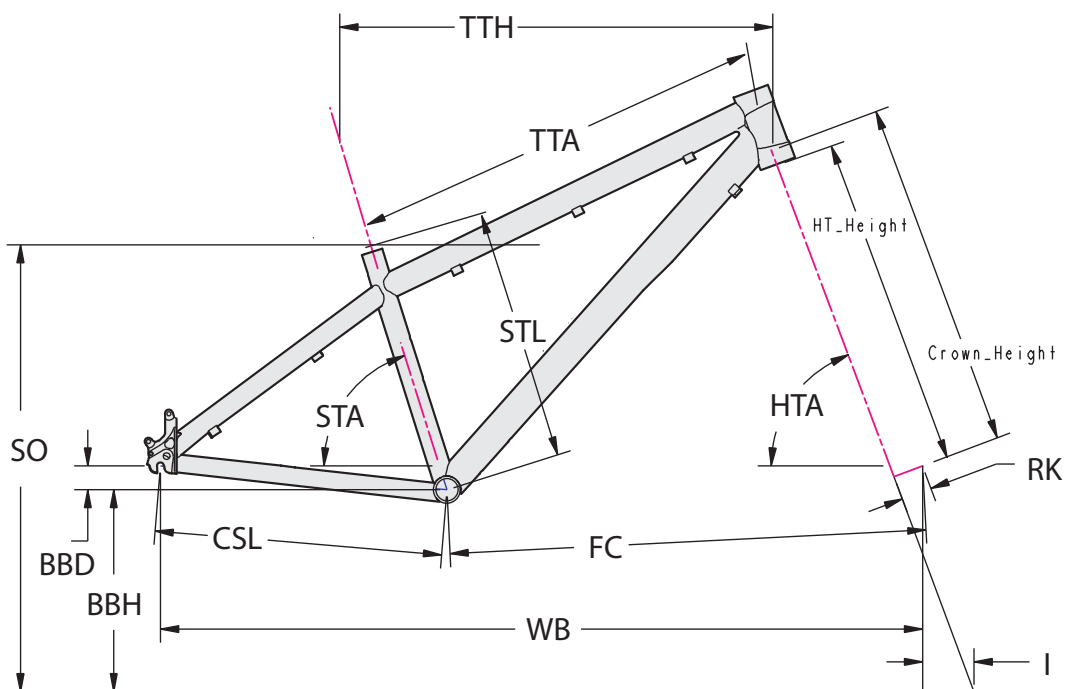

## FRAME SPECIFICATION

ITEM	SPECIFICATION
MODEL	CHASE
Frame material	6061-t6, tig welded, aluminum alloy
Sizes	S, M
Seatpost Diameter	27.2mm
Headtube	Headshok, OnePointFive
Bottom Bracket	73mm, English threaded
Dropout Spacing	135mm
Hub Spacing	135mm
Front Derailleur	31.8mm clamp-on
Rear Brake Mount	International Standard, 5"

## GEOMETRY

ITEM	REF	SMALL	MEDIUM
Seat tube angle (degree)	STA	77	77
Head tube angle (degree)	HTA	69	69
Horizontal top tube (cm)	TTH	54.3	57.5
Horizontal top tube actual (cm)	TTA	50.9	53.8
Seat tube length (cm)	STL	35.5	35.5
Chainstay length (cm)	CSL	40	40
Bottom bracket height (cm)	BBH	29.8	29.8
Bottom bracket drop	BBD	3.5	3.5
Wheelbase (cm)	WB	102.9	106.1
Stand over height (cm)	SO	72.7	72.7
Front-center distance (cm)	FC	63.2	66.4
Fork rake (cm)	RK	4.5	4.5
Fork trail (cm)	TR	8	8

## STREET/DIRT JUMP



### CHASE 1

Frame	▽	Chase Replica Hardtail
Fork	┌	RockShox Argyle 409 Solo Air 100mm w/Maxle
Rear Shock	▬	N/A
Rims	○	Sun Single Track, 32 hole
Hubs	⊥	Formula DC-91 front, Cannondale Fire rear
Spokes	✱	DT Swiss Champion
Tires	⋈	Maxxis Holy Roller, 26 x 2.4"
Pedals	⊞	Cannondale Grind Platform
Crank	⊕	FSA Nasty Boy, 34T w/ bashguard
Bottom Bracket	⊥	FSA BB-527
Chain	○	Shimano HG-53
Rear Cogs	≡	SRAM PG-970, 12-26
Front Derailleur	↗	N/A
Rear Derailleur	↘	SRAM X-0 short cage
Shifters	⊕	SRAM X-0 Trigger
Handlebar	┌	FSA FR-270 BOS, 40mm rise
Stem	┌	SIC Body Slam Classic 1 1/8" 31.8mm
Headset	⊕	FSA Orbit Z 1-1/8"
Brakes	⊞	Hayes HFX 9 w/ 7"/6" rotors
Brake Levers	┌	Hayes HFX 9
Saddle	┌	SDG I-SKY
Seatpost	┌	SDG I-Beam, 27.2 x 350mm
Sizes	▬	S,M
Color Code	┌	Lightning White (gloss) (WHT)
Extra's	...!	Cannondale Grind grips

Notes:

**cannondale**  
FEEL IT.

© Cannondale Bicycle Corp. V3 7/06. All prices and specifications subject to change without notice. • Orders subject to approval at our European headquarters.



## CHASE 2

Frame	∇	Chase Hardtail
Fork	∩	Marzocchi Dirt Jump 3 100mm Thru-20
Rear Shock	⊞	N/A
Rims	○	Sun Single Track, 32 hole
Hubs	⊞	Formula DC-91 front, Cannondale Fire rear
Spokes	✱	DT Swiss Champion
Tires	⊞	Maxxis Holy Roller, 26 x 2.4"
Pedals	⊞	Cannondale Grind Platform
Crank	⊞	TruVatiV Hussefelt, 26/36/ bashguard
Bottom Bracket	⊞	TruVatiV Howitzer
Chain	○	Shimano HG-53
Rear Cogs	≡	SRAM PG-950, 11-34
Front Derailleur	≡	Shimano Alivio
Rear Derailleur	≡	SRAM X-7 medium cage
Shifters	⊞	SRAM SX-5 Trigger
Handlebar	∩	FSA FR-330 BOS, 40mm rise
Stem	∩	Cannondale Freeride 1 1/8" 31.8mm
Headset	⊞	FSA Orbit Z 1-1/8"
Brakes	⊞	Hayes HFX 9 w/ 7"/6" rotors
Brake Levers	∩	Hayes HFX 9
Saddle	∩	SDG I-SKY
Seatpost	∩	SDG I-Beam, 27.2 x 350mm
Sizes	≡	S,M,L
Color Code	∩	Lightning White (gloss) (WHT)
Extra's	...!	Cannondale Grind grips

Notes:

## STREET/DIRT JUMP



### CHASE 3

Frame	▽	Chase Hardtail
Fork	┌	Marzocchi Dirt Jump 3 100mm
Rear Shock	▬	N/A
Rims	○	Sun Ditch Witch, 32 hole
Hubs	⊕	Cannondale Fire
Spokes	✱	DT Swiss Champion
Tires	▨	Kenda K-Rad, 26 x 2.3"
Pedals	⊕	Cannondale Grind Platform
Crank	⊕	TVV Ruktion, 36T
Bottom Bracket	⊕	TruVatiV Howitzer
Chain	○	SRAM PC-38
Rear Cogs	⊕	Sunrace M60, 11-32
Front Derailleur	┌	N/A
Rear Derailleur	⊕	SRAM SX-5
Shifters	⊕	SRAM SX-4 Trigger
Handlebar	┌	FSA FR-330 BOS, 40mm rise
Stem	┌	Cannondale Freeride 1 1/8" 31.8mm
Headset	⊕	FSA Orbit Z 1-1/8"
Brakes	⊕	Avid BB5 w/ 160mm rotors
Brake Levers	┌	Cannondale Earth
Saddle	┌	SDG I-SKY
Seatpost	┌	SDG I-Beam, 27.2 x 350mm
Sizes	▬	S,M,L
Color Code	┌	Raw Hi-Bright Aluminum (matte) (RAW)
Extra's	...!	Cannondale Grind grips
Notes:		



## CHASE 4

Frame	△	Chase SS Hardtail
Fork	∩	Marzocchi Dirt Jump 4 100mm
Rear Shock	⊞	N/A
Rims	○	Mach 1 2.30, 32 hole
Hubs	⊞	Cannondale Fire front, SS rear
Spokes	✱	DT Swiss Champion
Tires	⊞	Kenda K-Rad, 26 x 2.3"
Pedals	⊞	Cannondale Grind Platform
Crank	⊞	TVV Ruktion, 32T
Bottom Bracket	⊞	TruVatiV Howitzer
Chain	○	SRAM PC-38
Rear Cogs	⊞	included w/ rear hub
Front Derailleur	∩	N/A
Rear Derailleur	∩	N/A
Shifters	⊞	N/A
Handlebar	∩	FSA FR-330 BOS, 40mm rise
Stem	∩	Cannondale Freeride 1 1/8" 31.8mm
Headset	⊞	FSA Orbit Z 1-1/8"
Brakes	∩	Avid BB5 w/ 160mm rotors
Brake Levers	∩	Cannondale Earth
Saddle	∩	SDG I-SKY
Seatpost	∩	SDG I-Beam, 27.2 x 350mm
Sizes	⊞	S,M,L
Color Code	∩	Jet Black (matte) (BBQ)
Extra's	...!	Cannondale Grind grips
Notes:		



PROPHET MX

**ENDURO**

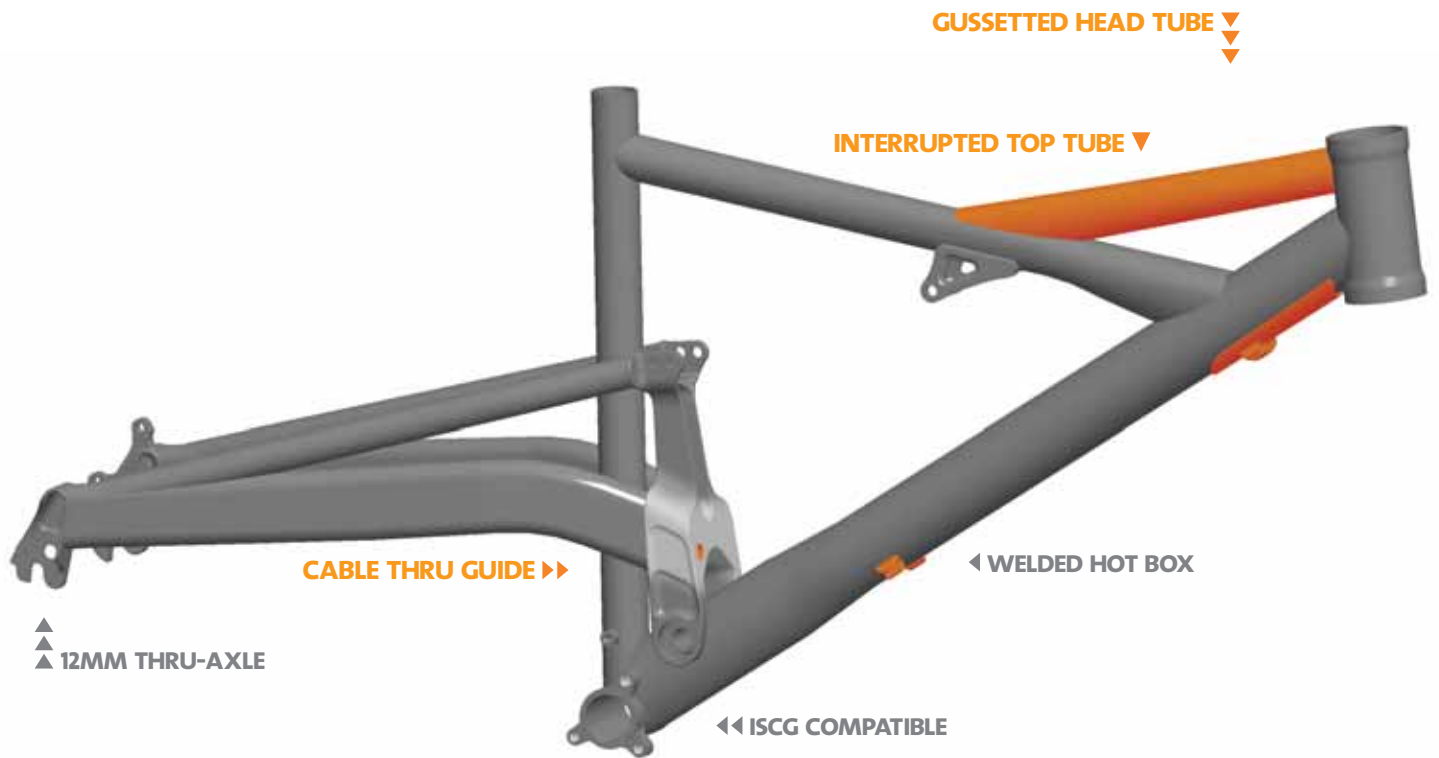

## PROPHET MX

### ▶ Interrupted top tube for increased stand over clearance.

- DE Das zweigeteilte Oberrohr ermöglicht eine größere Schrittfreiheit.
- ES Tubo vertical interrumpido para aumentar la distancia a la entrepierna.
- IT Tubo orizzontale interrotto per maggiore spazio al cavallo.
- FR Tube horizontal de type "interrompu" pour un meilleur dégagement d'entrejambe.
- NL Onderbroken bovenbuis geeft meer beenvrijheid.

### ▶▶ Cable thru guides so you can run full length shift housing. A must in muddy conditions

- DE Die Kabelführungen ermöglichen die Verlegung durchgehender Schaltkabel – ein Muss in schlammiger Umgebung.
- ES Guías gruesas para que puedas enfundar completamente el cable del cambio. Indispensable para la conducción en barro.
- IT Guide per far passare le guaine dei cambi senza interruzioni. Un must quando si sprofonda nel fango.
- FR L'utilisation de guide-câbles apporte une protection complète. Un plus indéniable dans les terrains boueux.
- NL Kabeldoorvoernokken langs het gehele frame zodat een volledige buitenkabel kan worden gemonteerd. Een noodzaak in modderige omstandigheden.

### ▶▶▶ Gusseted headtube/ downtube junction offers more big hit strength than the standard prophet frame.

- DE Die mit Gussets verstärkte Steuerrohr-/Unterrohrverbindung ist noch stabiler als die des Standard-Prophet-Rahmens und widersteht auch härtesten Schlägen.
- ES La unión reforzada de la pipa y el tubo diagonal garantiza una resistencia a los grandes impactos mayor que la del cuadro Prophet estándar.
- IT La giunzione rinforzata tubo sterzo/tubo obliquo offre maggiore resistenza ai grandi impatti rispetto al telaio Prophet standard.
- FR Le raccord tube de direction / tube diagonal à gousset apporte une résistance encore plus grande aux gros chocs que le cadre standard du Prophet.
- NL Versterkte bovenbuis/stuurbuis/onderbuis-driehoek geeft meer sterkte bij grote belasting dan bij het standaard Prophet-frame.

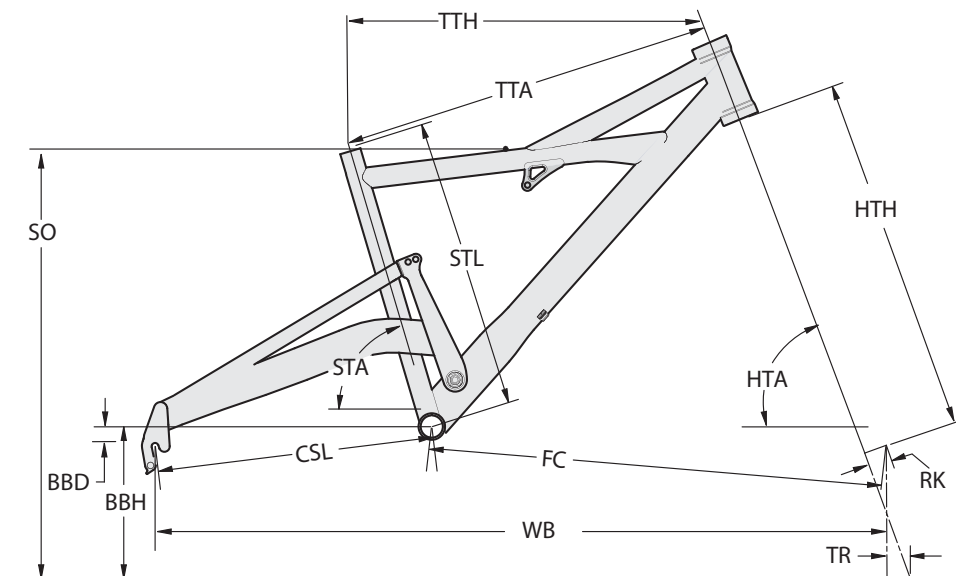

FRAME SPECIFICATION

ITEM	SPECIFICATION
MODEL	PROPHET MX
Frame material	6061-t6, tig welded, aluminum alloy
Sizes	S, M, L, X
Maximum tire width	64mm, 2.5in
Head tube	Headshok, OnePointFive
Maximum fork length	570mm
Seat post diameter	27.2 ±0.1mm
Rear shock bushing width (frame mount)	27.4 ±0.1mm
Rear shock bushing width (swingarm)	37.4 ±0.1mm
Bolt diameter	8.1 ±0.5mm
Rear shock eyelet-to-eyelet length	200 mm
Rear wheel travel	140mm
Rear shock stroke length	50mm
Rear shock leverage ratio	3:1 regressive
Front derailleur	Bottom pull top swing 31.8mm
Bottom bracket shell (width, thread type)	68mm, English E-Type
Chain line	47.5mm
Dropout spacing	135mm
Rear hub spacing	135mm
Rear axle	12mm thru axle
Rear brake mount	International standard, 6" or 8"

GEOMETRY

ITEM	REF	PETITE	SMALL	MEDIUM	LARGE	X-LARGE
Seat tube angle (degree)	STL	73.5 [75]	73.5 [75]	73.5 [75]	73.5 [75]	73.5 [75]
Head tube angle (degree)	HTA	67.5 [69]	67.5 [69]	67.5 [69]	67.5 [69]	67.5 [69]
Horizontal top tube (cm)	TTH	54.5	57.5	60	62.5	65
Horizontal top tube actual (cm)	TTA	50.4	53.2	55.8	59	62.8
Seat tube length (cm)	STL	40.5	40.5	43	48	53
Chainstay length (cm)	CSL	42	42	42	42	42
Bottom bracket height (cm)	BBH	33 [34.9]	33 [34.9]	33 [34.9]	33 [34.9]	33 [34.9]
Bottom bracket drop	BBD	0 [-1.9]	0 [-1.9]	0 [-1.9]	0 [-1.9]	0 [-1.9]
Wheelbase (cm)	WB	106	109	111.7	114.8	117.9
Stand over height (cm)	SO	74	74	74.5	75	75.9
Front-center distance (cm)	FC	64	67	69.7	72.8	75.9
Head tube height (cm)	HTH	52	52	52	52	52
Fork rake (cm)	RK	4.5	4.5	4.5	4.5	4.5
Fork trail (cm)	TR	8.8	8.8	8.8	8.8	8.8
Rear travel (cm)		14	14	14	14	14
Shock eye-to-eye (cm)		20	20	20	20	20
Shock stroke (cm)		5	5	5	5	5
Recommended sag (%)		25	25	25	25	25

All dimensions are given with suspension fully extended in FR and [XC] position.



PROPHET 1 MX

Frame	▽	Prophet Thru-12 140mm
Fork	┆	Fox 36 Float RC2 Air 160mm Thru-20
Rear Shock	▬	Fox DHX 5.0 Air
Rims	○	DT Swiss EX 5.1d, 32 hole
Hubs	┆	DT Swiss 340 Thru-20 front, Thru-12 rear
Spokes	✱	DT Swiss Champion
Tires	▨	Maxxis High Roller, 26 x 2.35"
Pedals	▬	N/A
Crank	⊕	TruVatiV Hussefelt, 24/36/PC guard
Bottom Bracket	┆	TruVatiV Howitzer
Chain	○	Shimano HG-73
Rear Cogs	▬	SRAM PG-990, 11-32
Front Derailleur	┆	Shimano XT
Rear Derailleur	┆	SRAM X-0 medium cage
Shifters	⊕	SRAM X-0 Trigger
Handlebar	┆	FSA FR-270 BOS, 40mm rise
Stem	┆	Cannondale Freeride Stem 1 1/8" 31.8mm
Headset	⊕	FSA Orbit Z 1-1/8"
Brakes	┆	Magura Louise Carbon BAT w/ 180mm VENTI rotors
Brake Levers	┆	Magura Louise Carbon BAT
Saddle	┆	Fi'zi:k Gobi w/ Ti rails
Seatpost	┆	FSA SP-FR-230, 27.2 x 350mm
Sizes	▬	S,M,L,X
Color Code	┆	Lightning White (gloss) (WHT)
Extra's	...!	Cannondale Grind grips

Notes:



PROPHET 2 MX

Frame	△	Prophet Thru-12 140mm
Fork	∩	RockShox Pike 426 Coil U-Turn 140mm w/Maxle
Rear Shock	⊞	RockShox Pearl 3.3 Air
Rims	○	Mavic EX325, 32 hole
Hubs	⊞	Formula Thru-20 front, Thru-12 rear
Spokes	✱	DT Swiss Champion
Tires	⊞	Maxxis High Roller, 26 x 2.35"
Pedals	⊞	N/A
Crank	⊞	TruVatiV Hussefelt, 24/36/PC guard
Bottom Bracket	⊞	TruVatiV Howitzer
Chain	○	SRAM 951
Rear Cogs	≡	SRAM PG-970, 11-34
Front Derailleur	≡	Shimano XT
Rear Derailleur	≡	SRAM X-9 medium cage
Shifters	⊞	SRAM X-9 Trigger
Handlebar	∩	FSA FR-330 BOS, 40mm rise
Stem	∩	Cannondale Freeride Stem 1 1/8" 31.8mm
Headset	⊞	FSA Orbit Z 1-1/8"
Brakes	⊞	Avid Juicy 7 w/ 185mm rotors
Brake Levers	∩	Avid Juicy 7
Saddle	∩	SDG BelAir ST
Seatpost	∩	SDG I-Beam, 27.2 x 350mm
Sizes	≡	S,M,L,X
Color Code	∩	Cut Team Replica (gloss) (REP)
Extra's	...!	Cannondale Grind grips
Notes:		



**PROPHET 3 MX**

Frame	▽	Prophet Thru-12 140mm
Fork	┆	RockShox Pike 409 Coil U-Turn 140mm w/Maxle
Rear Shock	▬	RockShox Pearl 2.1 Air
Rims	○	Sun Ditch Witch, 32 hole
Hubs	┆	Formula DC-91 front, DC-36 rear
Spokes	✱	DT Swiss Champion
Tires	▬	Maxxis High Roller, 26 x 2.35"
Pedals	▬	N/A
Crank	⊕	TruVatiV Ruktion, 24/36/PC guard
Bottom Bracket	┆	TruVatiV Howitzer
Chain	○	Shimano HG-53
Rear Cogs	▬	SRAM PG-950, 11-34
Front Derailleur	┆	Shimano LX
Rear Derailleur	┆	SRAM X-9 medium cage
Shifters	⊕	SRAM X-7 Trigger
Handlebar	┆	FSA FR-330 BOS, 40mm rise
Stem	┆	Cannondale Freeride Stem 1 1/8" 31.8mm
Headset	⊕	FSA Orbit Z 1-1/8"
Brakes	┆	Magura Louise w/ 180mm rotors
Brake Levers	┆	Magura Louise
Saddle	┆	SDG BelAir ST
Seatpost	┆	SDG I-Beam, 27.2 x 350mm
Sizes	▬	S,M,L,X
Color Code	┆	Jet Black (gloss) (BLK)
Extra's	...!	Cannondale Grind grips

Notes:



PROPHET

**ENDURO**

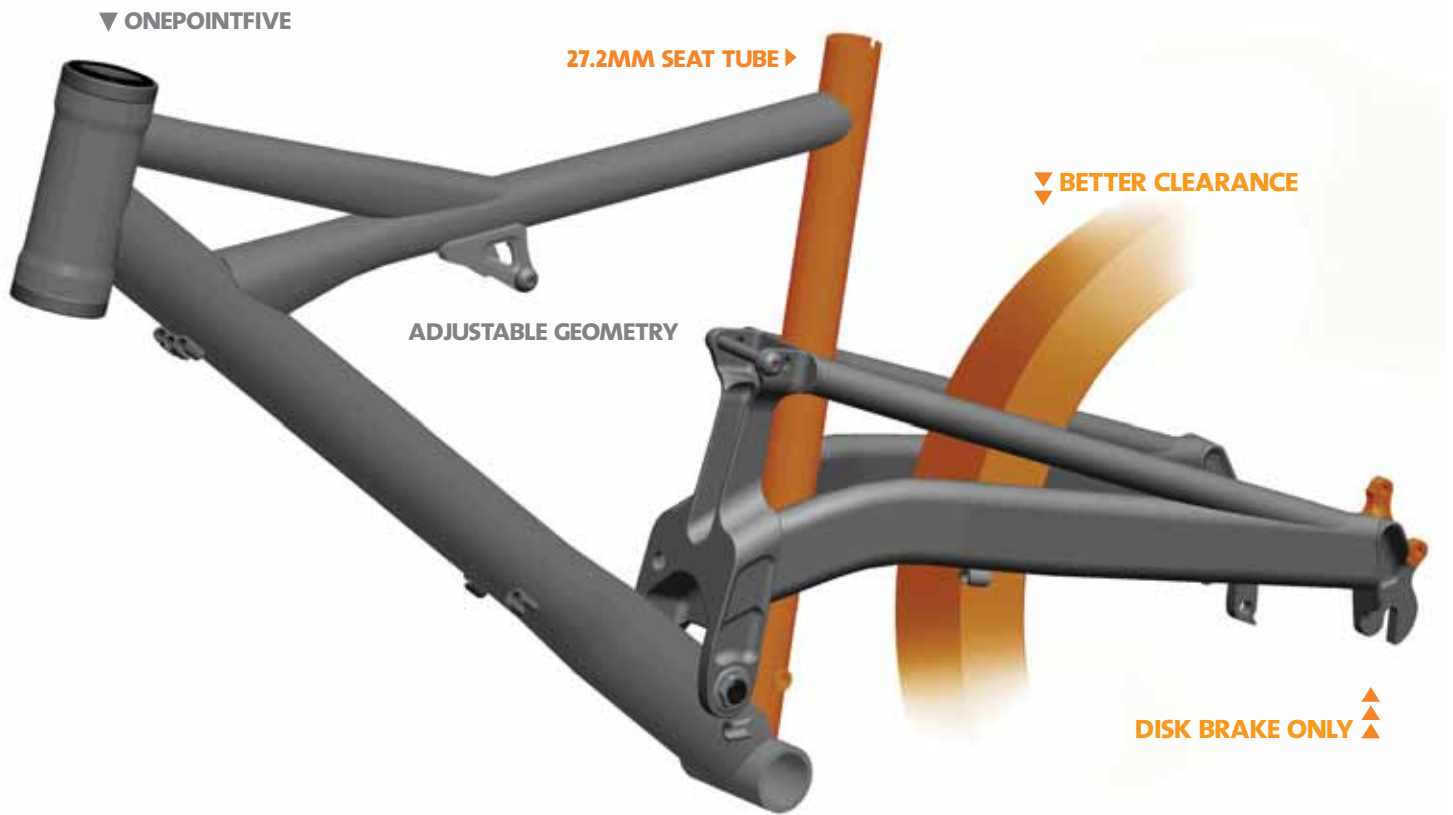

## PROPHET

### ▶ 27.2mm seat tube with integrated E-type derailleur mount.

- DE Sitzrohr mit 27,2 mm Innendurchmesser und integrierter E-Type-Umwerferbefestigung.
- ES Tubo conificado de 27.2 mm con anclaje integrado para desviadores tipo E.
- IT Tubo sella da 27.2 mm con attacco deragliatore integrato E-type.
- FR Tube de selle de 27,2 mm avec attache de dérailleur de type E intégrée.
- NL Geconificeerde 27,2mm buis met geïntegreerd E-type derailleurbevestigingspunt.

### ▶▶ Clearance for tires up to 2.5"

- DE Reifenfreiheit bis zu 2,5-Zoll-Reifen.
- ES Espacio para cubiertas de hasta 64mm (2,5").
- IT Spazio libero per gli pneumatici fino a 64mm (2,5").
- FR Grand dégagement permettant de monter des pneus jusqu'à 2,5 pouces.
- NL Bandvrijheid tot 2.5" banden.

### ▶▶▶ Disc brake only.

- DE Nur Scheibenbremsen-kompatibel.
- ES Compatible sólo con freno a disco.
- IT Solo freni a disco.
- FR Freins à disque uniquement.
- NL Alleen met schijfremmen.

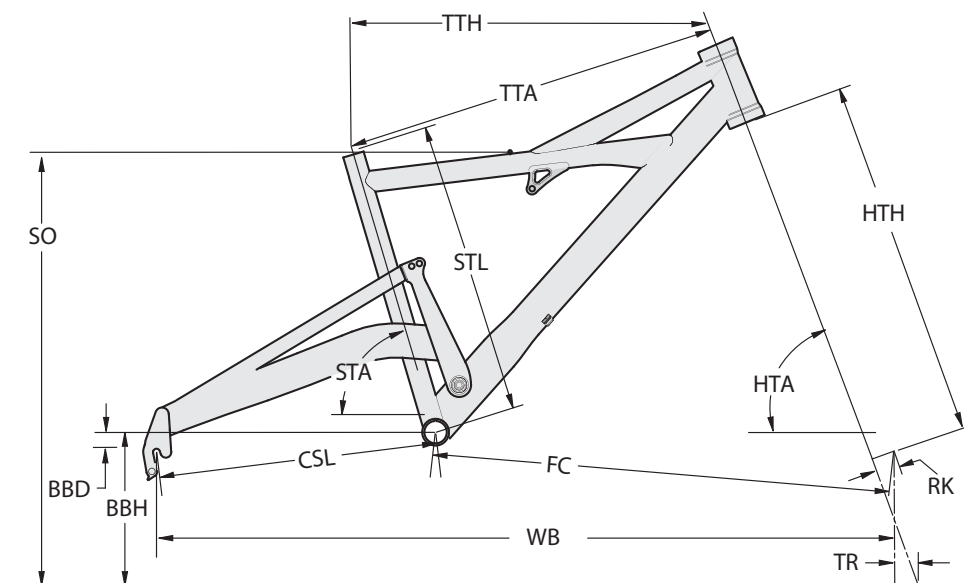

FRAME SPECIFICATION

ITEM	SPECIFICATION
MODEL	PROPHET
Frame material	6061-t6, tig welded, aluminum alloy
Sizes	S, M, L, X
Maximum tire width	64mm, 2.5in
Head tube	Headshok, OnePointFive
Maximum fork length	530mm
Seat post diameter	27.2 ±0.1mm
Rear shock bushing width (frame mount)	27.4 ±0.1mm
Rear shock bushing width (swingarm)	37.4 ±0.1mm
Bolt diameter	8.1 ±0.5mm
Rear shock eyelet-to-eyelet length	200 mm
Rear wheel travel	140mm
Rear shock stroke length	50mm
Rear shock leverage ratio	3:1 regressive
Front derailleur	Bottom pull top swing 31.8mm
Bottom bracket shell (width, thread type)	68mm, English E-Type
Chain line	47.5mm
Dropout spacing	135mm
Rear hub spacing	135mm
Rear axle	Quick release
Rear brake mount	International standard, 6" or 8"

GEOMETRY

ITEM	REF	PETITE	SMALL	MEDIUM	LARGE	X-LARGE
Seat tube angle (degree)	STL	73.5 [75]	73.5 [75]	73.5 [75]	73.5 [75]	73.5 [75]
Head tube angle (degree)	HTA	67.5 [69]	67.5 [69]	67.5 [69]	67.5 [69]	67.5 [69]
Horizontal top tube (cm)	TTH	54.5	57.5	60	62.5	65
Horizontal top tube actual (cm)	TTA	50.4	53.2	55.8	59	62.8
Seat tube length (cm)	STL	40.5	40.5	43	48	53
Chainstay length (cm)	CSL	42	42	42	42	42
Bottom bracket height (cm)	BBH	33 [34.9]	33 [34.9]	33 [34.9]	33 [34.9]	33 [34.9]
Bottom bracket drop	BBD	0 [-1.9]	0 [-1.9]	0 [-1.9]	0 [-1.9]	0 [-1.9]
Wheelbase (cm)	WB	106	109	111.7	114.8	117.9
Stand over height (cm)	SO	74	74	74.5	75	75.9
Front-center distance (cm)	FC	64	67	69.7	72.8	75.9
Head tube height (cm)	HTH	52	52	52	52	52
Fork rake (cm)	RK	4.5	4.5	4.5	4.5	4.5
Fork trail (cm)	TR	8.8	8.8	8.8	8.8	8.8
Rear travel (cm)		14	14	14	14	14
Shock eye-to-eye (cm)		20	20	20	20	20
Shock stroke (cm)		5	5	5	5	5
Recommended sag (%)		25	25	25	25	25

All dimensions are given with suspension fully extended in FR and [XC] position.

# ENDURO



## PROPHET 1

Frame	▽	Prophet 140mm
Fork	┆	Lefty Max Carbon 140 SPV
Rear Shock	▢	Manitou Swinger 3-Way Air
Rims	○	DT Swiss EX 5.1d, 32 hole
Hubs	▢	Cannondale Lefty front, DT Swiss 340 rear
Spokes	✱	DT Swiss Super Comp
Tires	▣	Maxxis Ignitor, 26 x 2.35"
Pedals	▢	crankbrothers smarty
Crank	⊕	FSA K-Force MegaExo Carbon, 22/32/44
Bottom Bracket	▢	FSA MegaExo
Chain	○	SRAM 991
Rear Cogs	▢	SRAM PG-990, 11-32
Front Derailleur	┆	Shimano XT
Rear Derailleur	┆	SRAM X-0
Shifters	⊕	SRAM X-0 Trigger
Handlebar	┆	FSA K-Force Carbon 1" rise
Stem	┆	Cannondale XC3 Headshok 31.8mm
Headset	⊕	Cannondale Headshok Si
Brakes	┆	Avid Juicy Carbon w/ 185/160mm rotors
Brake Levers	┆	Avid Juicy Carbon
Saddle	┆	SDG BelAir SL
Seatpost	┆	SDG I-Beam Carbon, 27.2 x 350mm
Sizes	▢	S,M,L,X
Color Code	┆	Galvanized (gloss) (GZD)
Extra's	...!	Cannondale Grind grips

Notes:



PROPHET 2



Cut Team Replica (gloss) (REP)

Frame	▽	Prophet 140mm
Fork	⌈	RockShox Pike 454 Dual Air 140mm w/Maxle
Rear Shock	⊞	RockShox Pearl 3,3 Air
Rims	○	Mavic XM321, 32 hole
Hubs	⊕	Formula DC-91 front, DT Swiss XC rear
Spokes	✱	DT Swiss Competition
Tires	⋯	Maxxis Ignitor, 26 x 2.35"
Pedals	⊞	crankbrothers smarty
Crank	⊕	FSA Afterburner MegaExo, 22/32/44
Bottom Bracket	⊞	FSA MegaExo
Chain	○	SRAM 951
Rear Cogs	⊞	SRAM PG-970, 11-34
Front Derailleur	⌋	Shimano LX
Rear Derailleur	⌋	SRAM X-9
Shifters	⊕	SRAM X-7 Trigger
Handlebar	⌋	FSA XC-282-AOS, 25mm rise
Stem	⌋	FSA OS-150 XTC 31.8mm
Headset	⊕	FSA Orbit DL 1-1/8"
Brakes	⌋	Avid Juicy 7 w/ 185/160mm rotors
Brake Levers	⌋	Avid Juicy 7
Saddle	⌋	SDG BelAir SL
Seatpost	⌋	SDG I-BEAM SL, 27.2 x 350mm
Sizes	⌋	S,M,L,X
Color Code	⌋	Cut Team Replica (gloss) (REP)
Extra's	⋯!	Lightning White (gloss) (WHT)
Notes:		Cannondale Grind grips

## ENDURO



## PROPHET 3

Frame	▽	Prophet 140mm
Fork	┌	RockShox Pike 409 Coil U-Turn 140mm w/Maxle
Rear Shock	⊞	Manitou Radium RL Air
Rims	○	Sun Ditch Witch, 32 hole
Hubs	⊞	Formula DC-91 front, Formula DC-58 rear
Spokes	✱	DT Swiss Champion
Tires	⋈	Maxxis Ignitor, 26 x 2.35"
Pedals	⊞	Welgo Clipless
Crank	⊞	FSA Alpha Drive, 22/32/44
Bottom Bracket	⊞	FSA ISIS SL
Chain	○	Shimano HG-53
Rear Cogs	≡	SRAM PG-950, 11-34
Front Derailleur	≡	Shimano LX
Rear Derailleur	≡	SRAM X-9
Shifters	⊞	SRAM X-7 Trigger
Handlebar	┌	FSA XC-282-AOS, 25mm rise
Stem	┌	FSA OS-150 XTC 31.8mm
Headset	⊞	FSA Orbit DL 1-1/8"
Brakes	⊞	Avid Juicy 5 w/ 185/160mm rotors
Brake Levers	┌	Avid Juicy 5
Saddle	┌	SDG BelAir SL
Seatpost	┌	SDG I-BEAM SL, 27.2 x 350mm
Sizes	≡	S,M,L,X
Color Code	┌	Lightning White (gloss) (WHT) Teak Brown (matte) (BRN)
Extra's	...!	Cannondale Grind grips



Lightning White (gloss) (WHT)



PROPHET 4



Jet Black (matte) (BBQ)

Frame	△	Prophet 140mm
Fork	∩	RockShox Tora 318 Coil U-Turn 130mm
Rear Shock	⊞	Manitou Radium RL Air
Rims	○	Mach 1 2.30, 32 hole
Hubs	⊞	Shimano M475
Spokes	✱	DT Swiss Champion
Tires	⊞	Maxxis Ignitor, 26 x 2.35"
Pedals	⊞	Wellgo alloy cage w/ clip and strap
Crank	⊞	Truvativ IsoFlow, 22/32/44
Bottom Bracket	⊞	Shimano BB-UN26
Chain	○	Shimano HG-53
Rear Cogs	≡	SRAM PG-950, 11-34
Front Derailleur	≡	Shimano LX
Rear Derailleur	≡	SRAM X-7
Shifters	⊞	SRAM SX-5 Trigger
Handlebar	∩	Cannondale C3, 20mm rise
Stem	∩	Cannondale XC3 1 1/8" 31.8mm
Headset	⊞	FSA Orbit DL 1-1/8"
Brakes	⊞	Avid Juicy 3 w/ 185/160mm rotors
Brake Levers	∩	Avid Juicy 3
Saddle	∩	Fi'zi:k Plateau w/ Cr-Mo rails
Seatpost	∩	Cannondale C4, 27.2 x 350mm
Sizes	≡	S,M,L,X
Color Code	∩	Raw Hi-Bright Aluminum (matte) (RAW) Jet Black (matte) (BBQ)
Extra's	...!	Cannondale V-Tech grips
Notes:		



*PROPHET SL*

**ALL MOUNTAIN**

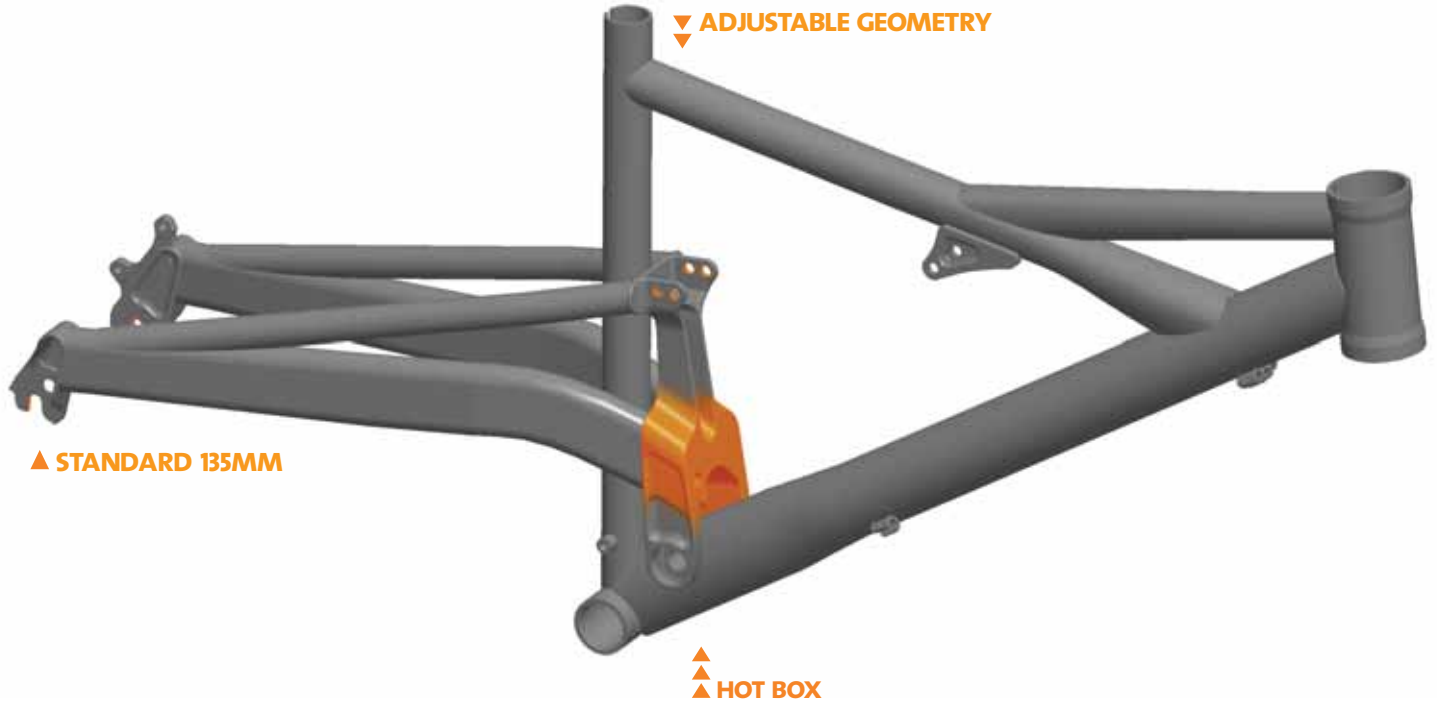

## PROPHET SL

### ▶ 120mm rear travel with adjustable geometry for 67.5 or 69 head tube angles.

- DE 120 mm Federweg am Hinterrad; verstellbare Geometrie mit 67,5 oder 69 Grad Steuerrohrwinkel.
- ES 120mm de recorrido de la rueda trasera con geometría ajustable (pipa de dirección con ángulo de 67.5 o 69 grados).
- IT 120mm di escursione con geometria regolabile per angoli del tubo sterzo da 67.5 o 69 gradi.
- FR Débattement arrière de 120 mm et angle du tube de direction réglable à 67,5° ou 69°.
- NL 120mm veerweg achter met verstelbare geometrie voor 67.5 of 69 graden balhoofdhoek.

### ▶▶ Standard 135mm quick release rear drop outs for light weight and broad wheel compatibility.

- DE Das 135 mm breite Standardausfallende wiegt wenig und ist mit den allermeisten Hinterradnaben kompatibel.
- ES Punteras estándar de 135 mm con cierre rápido. Ligereza y máxima compatibilidad.
- IT Forcellini posteriori standard a rilascio rapido di 135 mm per leggerezza e compatibilità per le ruote più larghe.
- FR Les pattes de blocage rapide arrière standard de 135 mm sont légères et compatibles avec une grande variété de roues.
- NL Standaard 135mm quick release uitvalpatten achter voor gewichtsbesparing en grote uitwisselbaarheid van wielen.

### ▶▶▶ Stiff yet lightweight, the Hot Box, a welded hollow core swing arm pivot is the answer to the stiff or light question... have both!

- DE Die Hot Box ist als geschweißter, hohler Schwingengelenksbereich ausgeführt und löst den unendlichen Konflikt Leicht versus Steif... jetzt gibt es beides in einem!
- ES Rígida y ligera. La caja soldada del pivote del basculante Hot Box es la respuesta a la vieja pregunta ¿rígida o ligera? ¡Ahora no tienes que renunciar a nada!
- IT Rigido ma leggero l'Hot Box, un fulcro del forcellone saldato e cavo, è la risposta al dilemma tra rigidità e leggerezza... potete avere entrambe!
- FR Rigide et ultra léger, le pivot de bras oscillant à corps creux soudé "Hot Box" apporte la réponse au dilemme rigidité/légèreté : vous bénéficiez des deux à la fois !
- NL Stijf en tegelijkertijd lichtgewicht, de 'Hot Box', een gelast swingarmdraaipunt met holle kern is het antwoord op de keuzevraag licht of stijf... Waarom niet allebei!

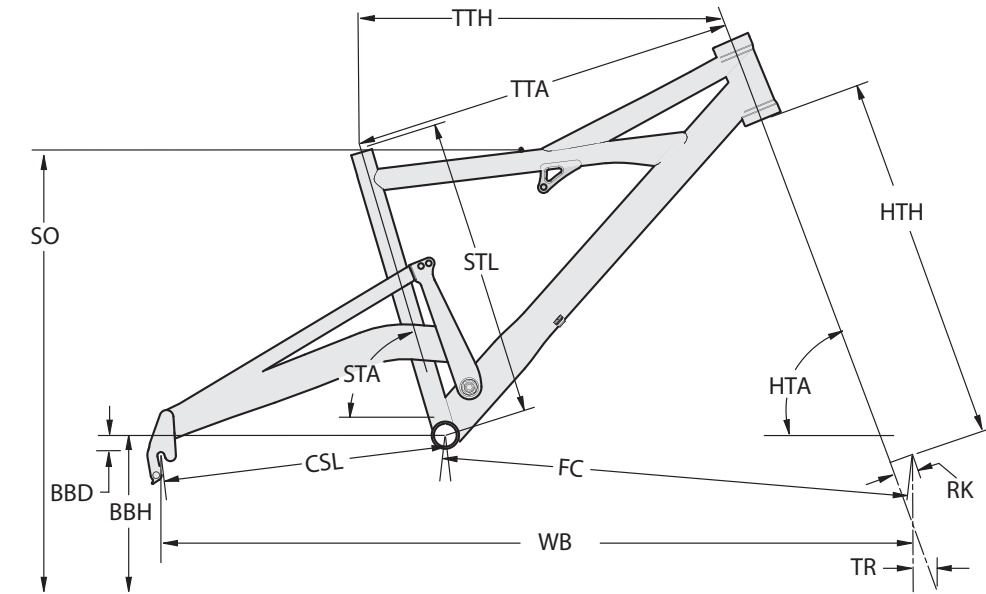

FRAME SPECIFICATION

ITEM	SPECIFICATION
MODEL	PROPHET
Frame material	6061-t6, tig welded, aluminum alloy
Sizes	S, M, L, X
Maximum tire width	64mm, 2.5in
Head tube	Headshok, OnePointFive
Maximum fork length	530mm
Seat post diameter	27.2 ±0.1mm
Rear shock bushing width (frame mount)	27.4 ±0.1mm
Rear shock bushing width (swingarm)	37.4 ±0.1mm
Bolt diameter	8.1 ±0.5mm
Rear shock eyelet-to-eyelet length	200 mm
Rear wheel travel	140mm
Rear shock stroke length	50mm
Rear shock leverage ratio	3:1 regressive
Front derailleur	Bottom pull top swing 31.8mm
Bottom bracket shell (width, thread type)	68mm, English E-Type
Chain line	47.5mm
Dropout spacing	135mm
Rear hub spacing	135mm
Rear axle	Quick release
Rear brake mount	International standard, 6" or 8"

GEOMETRY

ITEM	REF	SMALL	MEDIUM	LARGE	X-LARGE
Seat tube angle (degree)	STL	73.5 [75]	73.5 [75]	73.5 [75]	73.5 [75]
Head tube angle (degree)	HTA	67.5 [69]	67.5 [69]	67.5 [69]	67.5 [69]
Horizontal top tube (cm)	TTH	57.5	60	62.5	65
Horizontal top tube actual (cm)	TTA	53.2	55.8	59	62.8
Seat tube length (cm)	STL	40.5	43	48	53
Chainstay length (cm)	CSL	42	42	42	42
Bottom bracket height (cm)	BBH	32.9	32.9	32.9	32.9
Bottom bracket drop	BBD	2.5	2.5	2.5	2.5
Wheelbase (cm)	WB	108.2	110.9	114	117.1
Stand over height (cm)	SO	72.4	72.5	73	73.9
Front-center distance (cm)	FC	66.2	66.2	66.2	66.2
Head tube height (cm)	HTH	52	52	52	52
Fork rake (cm)	RK	4.5	4.5	4.5	4.5
Fork trail (cm)	TR	8.8	8.8	8.8	8.8
Rear travel (cm)		12	12	12	12
Shock eye-to-eye (cm)		19	19	19	19
Shock stroke (cm)		4.44	4.44	4.44	4.44
Recommended sag (%)		20	20	20	20

All dimensions are given with suspension fully extended in FR and [XC] position.

## ALL MOUNTAIN



### PROPHET 1 SL

Frame	▽	Prophet 120mm
Fork	┌	Fox 32 Float RLC 120mm
Rear Shock	▢	Fox Float RP3 Air
Rims	○	Mavic CrossMax ST UST
Hubs	⊥	Mavic CrossMax ST
Spokes	✱	Mavic CrossMax ST
Tires	▨	Maxxis CrossMark UST, 26 x 2.1"
Pedals	⊞	N/A
Crank	⊕	FSA K-Force MegaExo Carbon, 22/32/44
Bottom Bracket	⊥	FSA MegaExo
Chain	○	SRAM 991
Rear Cogs	≡	SRAM PG-990, 11-32
Front Derailleur	↗	Shimano XT
Rear Derailleur	↘	SRAM X-0
Shifters	⊕	SRAM X-9 Trigger
Handlebar	┌	FSA K-Force Carbon, 25mm rise
Stem	┌	FSA OS-150 XTC 31.8mm
Headset	⊕	FSA Orbit Xtreme Pro 1.5"
Brakes	⊞	Avid Juicy Carbon w/ 185/160mm rotors
Brake Levers	┌	Avid Juicy Carbon
Saddle	∪	Fi'zi:k Gobi w/ Ti rails
Seatpost	┌	FSA SL-K Carbon, 27.2 x 350mm
Sizes	≡	S,M,L,X
Color Code	┌	Fine Silver (gloss) (SLV)
Extra's	...!	Cannondale V-Tech grips
Notes:		



PROPHET 2 SL

Frame	▧	Prophet 120mm
Fork	┆	RockShox Revelation 426 Dual Air 120mm
Rear Shock	▩	Fox Float RP3 Air
Rims	○	Mavic XM317 Disc, 32 hole
Hubs	┆	DT Swiss XC Disc
Spokes	✱	DT Swiss Competition
Tires	⋯	Maxxis Ignitor, 26 x 2.1"
Pedals	▩	crankbrothers candy c
Crank	⊕	FSA Afterburner MegaExo, 22/32/44
Bottom Bracket	┆	FSA MegaExo
Chain	○	SRAM 951
Rear Cogs	≡	SRAM PG-970, 11-34
Front Derailleur	↗	Shimano LX
Rear Derailleur	↘	SRAM X-9
Shifters	⊕	SRAM X-7 Trigger
Handlebar	┆	FSA XC-282-AOS, 25mm rise
Stem	┆	FSA OS-150 XTC 31.8mm
Headset	⊕	FSA Orbit DL 1-1/8"
Brakes	⊕	Avid Juicy 7 w/ 185/160mm rotors
Brake Levers	┆	Avid Juicy 7
Saddle	▩	Cannondale 71 All Mountain w/Ti rails
Seatpost	┆	Cannondale C3, 27.2 x 350mm
Sizes	▩	S,M,L,X
Color Code	┆	Patriot Blue (gloss) (BLU)
Extra's	...!	Cannondale V-Tech grips
Notes:		

## ALL MOUNTAIN



### PROPHET 3 SL

Frame	▽	Prophet 120mm
Fork	┌	RockShox Recon 351 Solo Air 120mm
Rear Shock	▬	Fox Float R Air
Rims	○	Mavic XM117 Disc, 32 hole
Hubs	⊥	Shimano M475
Spokes	✱	DT Swiss Champion
Tires	⋈	Hutchinson Spider, 26 x 2.0"
Pedals	⊞	Welgo Clipless
Crank	⊕	FSA Gamma Drive, 22/32/44
Bottom Bracket	⊥	FSA ISIS SL
Chain	○	Shimano HG-53
Rear Cogs	≡	SRAM PG-950, 11-34
Front Derailleur	↗	Shimano LX
Rear Derailleur	↘	Shimano XT
Shifters	⊕	Shimano Deore RAPIDFIRE plus
Handlebar	┌	Cannondale Fire, 20mm rise
Stem	┌	Cannondale XC3 1 1/8" 25.4mm
Headset	⊕	FSA Orbit DL 1-1/8"
Brakes	⊞	Avid Juicy 3 w/ 185/160mm rotors
Brake Levers	┌	Avid Juicy 3
Saddle	┌	Cannondale 71 All Mountain
Seatpost	┌	FSA SP-FR-270, 27.2 x 350mm
Sizes	▬	S,M,L,X
Color Code	┌	Jet Black (gloss) (BLK)
Extra's	...!	Cannondale V-Tech grips

Notes:



**RUSH** CARBON

# MARATHON

## SYSTEM INTEGRATION ▼



FULL CARBON MAINFRAME ▶

MASSIVE CARBON TOPTUBE ▶▶

◀◀ WELDED HOT BOX

LIGHTER AND STIFFER BB ▶▶▶

## RUSH CARBON

▶ System Integration, with an integrated headset we can deliver an ever lighter, race worthy machine.

- DE Durch Systemintegration (integrierter Steuersatz) wird unsere Maschine noch leichter und noch renntauglicher.
- ES Integración de sistemas. Con una dirección integrada podemos reducir el peso mejorando su rendimiento en competición.
- IT System Integration, con una serie sterzo integrata possiamo fornirvi una bici da gara leggera come non mai.
- FR Système Intégré. Ce vélo taillé pour la compétition est encore plus léger grâce au jeu de direction intégré.
- NL System Integration, met een geïntegreerd balhoofdlager kunnen we een nog lichtere race-machine afleveren.

▶▶ Massive Carbon top tube is very stiff, while also absorbing energy sapping vibrations.

- DE Das massive Carbon-Oberrohr ist extrem steif. Gleichzeitig absorbiert es energiefressende Vibrationen.
- ES El enorme tubo horizontal de carbono es increíblemente rígido y absorbe las vibraciones.
- IT Il massiccio tubo orizzontale in carbonio è rigidissimo ma riesce ad assorbire le vibrazioni succhia-energia.
- FR Le tube horizontal en carbone est non seulement extrêmement rigide mais il permet aussi d'absorber les vibrations.
- NL Massieve carbon bovenbuis is zeer stijf maar absorbeert tegelijkertijd energievretende trillingen.

▶▶▶ SI BB shell is lighter and stiffer than much of the competition, and a Cannondale exclusive

- DE Das SI-Tretlager ist leichter und steifer als die meisten konkurrierenden Konstruktionen und nur bei Cannondale erhältlich.
- ES El eje de pedalier SI exclusivo de Cannondale es más ligero y rígido que los de casi todas las otras marcas.
- IT La scatola del movimento centrale SI è più leggera e più rigida della maggior parte di quelle della concorrenza ed è un'esclusiva Cannondale.
- FR Le boîtier de pédalier SI est plus léger et plus rigide que la plupart de ses concurrents. Une exclusivité Cannondale.
- NL SI BB-trapashuis is lichter en stijver dan die van de meeste concurrenten, en een exclusief Cannondale-ontwerp.

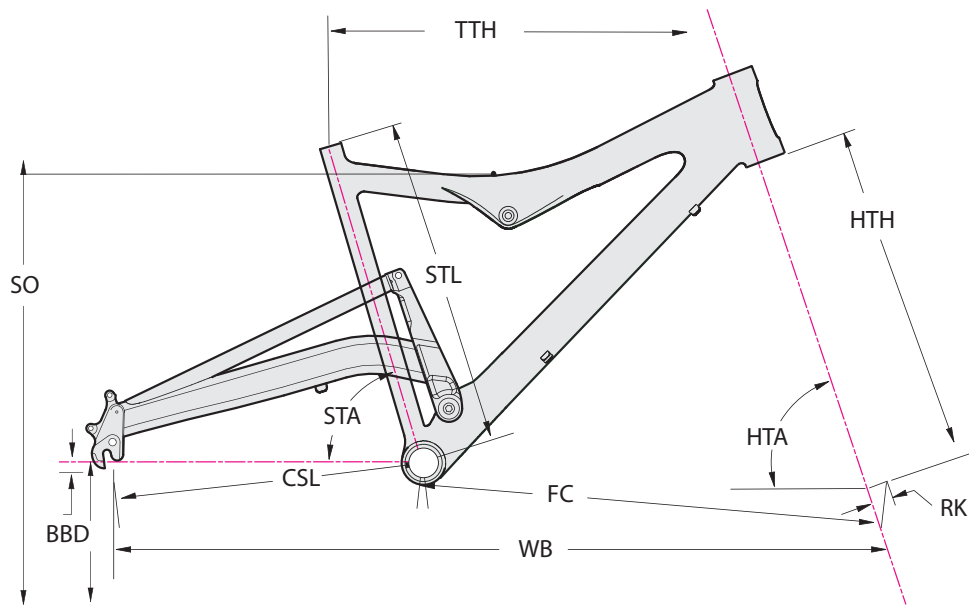

FRAME SPECIFICATION

GEOMETRY

ITEM	SPECIFICATION
MODEL	RUSH CARBON SI
Frame material	Carbon fiber
Sizes	S, M, L, X
Seatpost Diameter	27.2mm
Headtube	Cannondale System Integration
Rear Shock Eye-to-Eye	190mm
Rear Wheel Travel	110mm
Bottom Bracket	Cannondale System Integration
Dropout Spacing	135mm
Hub Spacing	135mm
Front Derailleur	31.8mm clamp-on
Rear Wheel Travel	110mm
Rear Shock Eye-to-Eye	190mm
Rear Shock stroke	45mm
Rear Brake Mount	International Standard, 6"
Recommended sag	25%

ITEM	REF	SMALL	MEDIUM	LARGE	X-LARGE
Seat tube angle (degree)	STA	73.5°	73.5°	73.5°	73.5°
Head tube angle (degree)	HTA	69°	69°	69°	69°
Horizontal top tube (cm)	TTA	56	60	62.5	65
Seat tube length (cm)	STL	40.5	43	48	50
Chainstay length (cm)	CSL	42.2	42.2	42.2	42.2
Bottom bracket height (cm)	BBH	32	32	32	32
Wheelbase (cm)	WB	106	110.2	113.1	115.8
Trail (cm)	TR	7.9	7.9	7.9	7.9
Stand over height (cm)	SO	74.9	75.2	74.5	74.4
Bottom bracket drop (cm)	BBD	1	1	1	1
Front-center distance (cm)	FC	63.9	68.1	71	73.7
Fork rake (cm)	RK	4.5	4.5	4.5	4.5

\* All dimensions: suspension fully extended.

## MARATHON



## RUSH CARBON TEAM

Frame	▽	Rush Carbon Si 110mm
Fork	┆	Lefty Speed Carbon SL 110 DLR2
Rear Shock	▢	Fox Float RP3 Air
Rims	○	Mavic CrossMax SLR UST
Hubs	┆	Mavic CrossMax SLR
Spokes	✱	Mavic CrossMax SLR
Tires	▨	Maxxis CrossMark UST, 26 x 2.1"
Pedals	▢	N/A
Crank	⊕	Cannondale Hollowgram Si, 22/32/44
Bottom Bracket	┆	Cannondale Si
Chain	○	SRAM 991
Rear Cogs	▴	SRAM PG-990, 11-32
Front Derailleur	┆	Shimano XTR
Rear Derailleur	⚙	SRAM X-0
Shifters	⊕	SRAM X-0 Trigger
Handlebar	┆	FSA K-Force Carbon Flat
Stem	┆	Cannondale Si one piece Stem/Steerer 31.8mm
Headset	⊕	Cannondale Headshok Si
Brakes	⚙	Avid Juicy Ultimate w/ 160/140mm rotors
Brake Levers	┆	Avid Juicy Ultimate
Saddle	┆	Fi'zi:k Gobi w/ Ti rails
Seatpost	┆	FSA K Force Lite Carbon SB-25, 27.2 x 350mm
Sizes	▢	S,M,L,X
Color Code	┆	Uni Carbon w/ Silver/Grey (gloss) (GRY) Uni Carbon w/ Patriot Blue (gloss) (BLU)
Extra's	...!	Cannondale V-Tech grips



Uni Carbon w/ Silver/Grey (gloss) (GRY)



RUSH CARBON 1



Uni Carbon w/ Silver/Grey (gloss) (GRY)

Frame	△	Rush Carbon Si 110mm
Fork	∩	Lefty Speed Carbon SL 110 DLR2
Rear Shock	⊞	Fox Float RPL Air
Rims	○	Mavic CrossMax SLR UST
Hubs	⊞	Mavic CrossMax SLR
Spokes	✱	Mavic CrossMax SLR
Tires	⊞	Maxxis CrossMark UST, 26 x 2.1"
Pedals	⊞	crankbrothers candy c
Crank	⊞	Shimano XTR, 22/32/44
Bottom Bracket	⊞	Shimano XTR
Chain	○	Shimano CN-7701
Rear Cogs	≡	Shimano XTR, 11-34
Front Derailleur	≡	Shimano XTR
Rear Derailleur	≡	Shimano XTR
Shifters	⊞	Shimano XTR RAPIDFIRE plus
Handlebar	∩	FSA K-Force Carbon Flat
Stem	∩	Cannondale Si one piece Stem/Steerer 31.8mm
Headset	⊞	Cannondale Headshok Si
Brakes	⊞	Shimano XTR w/ 160mm rotors
Brake Levers	∩	Shimano XTR
Saddle	∩	Fi'zi:k Gobi w/ Ti rails
Seatpost	∩	FSA K Force Lite Carbon SB-25, 27.2 x 350mm
Sizes	≡	S,M,L,X
Color Code	∩	Uni Carbon w/ Silver/Grey (gloss) (GRY) Uni Carbon w/ Patriot Blue (gloss) (BLU)
Extra's	...!	Cannondale V-Tech grips
Notes:		

## MARATHON



## RUSH CARBON 2

Frame	△	Rush Carbon Si 110mm
Fork	∩	Lefty Speed Carbon 110 DLR2
Rear Shock	⊞	Fox Float RPL Air
Rims	○	Mavic XM819 Disc UST, 24 hole
Hubs	⊞	Cannondale Lefty front, Sun Ringle Dirty Flea rear
Spokes	✱	DT Swiss Super Comp
Tires	⋯	Maxxis CrossMark UST, 26 x 2.1"
Pedals	⊞	crankbrothers candy c
Crank	⊞	Cannondale Carbon Si 2-piece, 22/32/44
Bottom Bracket	⊞	Cannondale Si
Chain	○	Shimano HG-73
Rear Cogs	≡	Shimano XT, 11-34
Front Derailleur	≡	Shimano XT
Rear Derailleur	≡	Shimano XT
Shifters	⊞	Shimano XT RAPIDFIRE plus
Handlebar	∩	ControlTech Carbon Flat
Stem	⊞	Cannondale Si one piece Stem/Steerer 31.8mm
Headset	⊞	Cannondale Headshok Si
Brakes	⊞	Avid Juicy 7 w/ 160mm rotors
Brake Levers	∩	Avid Juicy 7
Saddle	∩	Fi'zi:k Nisene HP w/ Ti rails
Seatpost	∩	ControlTech Carbon, 27.2 x 350mm
Sizes	≡	S,M,L,X
Color Code	⊞	Uni Carbon w/ Silver/Grey (gloss) (GRY) Uni Carbon w/ Patriot Blue (gloss) (BLU)
Extra's	...!	Cannondale V-Tech grips



Uni Carbon w/ Patriot Blue (gloss) (BLU)



RUSH CARBON 3



Uni Carbon w/ Patriot Blue (gloss) (BLU)

Frame	▽	Rush Carbon Si 110mm
Fork	∩	Lefty Speed 110 DLR2
Rear Shock	⊞	Fox Float RPL Air
Rims	○	Mavic XM819 Disc UST, 24 hole
Hubs	⊞	Cannondale Lefty front, DT Swiss XC rear
Spokes	✱	DT Swiss Competition
Tires	⋯	Maxxis CrossMark UST, 26 x 2.1"
Pedals	⊞	crankbrothers candy c
Crank	⊞	FSA Afterburner MegaExo, 22/32/44
Bottom Bracket	⊞	FSA MegaExo
Chain	○	SRAM 951
Rear Cogs	≡	SRAM PG-970, 11-34
Front Derailleur	↗	Shimano LX
Rear Derailleur	↘	SRAM X-9
Shifters	⊞	SRAM X-7 Trigger
Handlebar	∩	FSA XC190-AOS, 25mm rise
Stem	⊞	Cannondale Si one piece Stem/Steerer 31.8mm
Headset	⊞	Cannondale Headshok Si
Brakes	⊞	Avid Juicy 7 w/ 160mm rotors
Brake Levers	∩	Avid Juicy 7
Saddle	∩	Fi'zi:k Nisene Sport
Seatpost	∩	Cannondale C3 offset, 27.2 x 350mm
Sizes	⊞	S,M,L,X
Color Code	⊞	Uni Carbon w/ Silver/Grey (gloss) (GRY) Uni Carbon w/ Patriot Blue (gloss) (BLU)
Extra's	...!	Cannondale V-Tech grips

Notes:



RUSH

# MARATHON

## MARATHON

### ULTIMATE MARATHON GEOMETRY

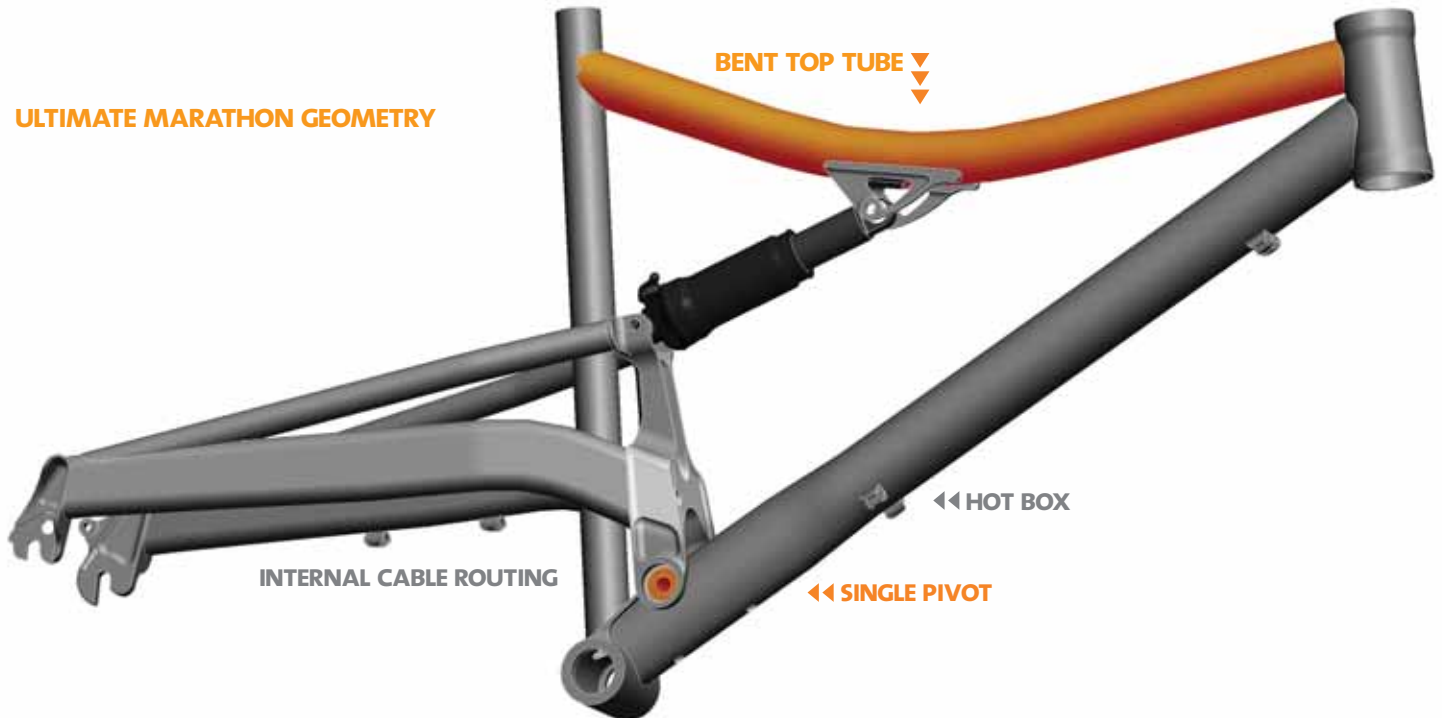

## RUSH ALLOY

► Ultimate marathon geometry provides the ride and handling needed when you are past your second wind.

- DE Die ultimative Marathongeometrie verschafft die Fahreigenschaften und das Handling, die benötigt werden, wenn auch der zweite Kick verflogen ist.
- ES Una geometría de maratón perfecta que te proporciona el control y la agilidad que necesitas cuando te acercas al límite de tus fuerzas.
- IT La sua geometria speciale "marathon" garantisce la manovrabilità e l'efficacia che avete bisogno quando correte al limite delle vostre forze.
- FR Sa géométrie spécial marathon apporte toute la maniabilité et l'efficacité dont vous avez besoin lorsque vous courez après votre second souffle.
- NL Ultieme marathon-geometrie geeft je de rijeigenschappen die je nodig hebt als je je tweede adem voorbij bent

►► Single pivot for efficiency, low weight and ease of maintenance.

- DE Niedriges Gewicht und geringer Wartungsaufwand durch Eingelenkskonstruktion.
- ES Pivote único para lograr una mayor eficacia, un menor peso y un sencillo mantenimiento.
- IT Fulcro singolo per efficienza, riduzione del peso e facile manutenzione.
- FR Système à pivot unique, pour gagner en efficacité, en poids et en facilité d'entretien.
- NL Enkel draaipunt voor efficiëntie, laag gewicht en eenvoudig onderhoud.

►►► Top tube bend minimizes material and weight while providing maximum top tube clearance needed for the sketchy sections.

- DE Die Biegung im Oberrohr minimiert den Materialeinsatz und das Gewicht. Außerdem gewährleistet sie die für schwierige Sektionen notwendige Schrittfreiheit.
- ES La curvatura del tubo superior contribuye a reducir el peso y te permite una mayor libertad de movimientos en las secciones más técnicas.
- IT L'ultimissima geometria per la maratona fornisce le prestazioni e la maneggevolezza di cui avete bisogno quando avete dato fondo alle vostre energie.
- FR La courbure du tube horizontal permet de réduire la quantité de matériau et le poids tout en apportant le dégagement nécessaire au niveau du tube horizontal.
- NL Gebogen bovenbuis minimaliseert materiaalgebruik en gewicht en geeft maximale bewegingsvrijheid in de lastige delen van het parcours.

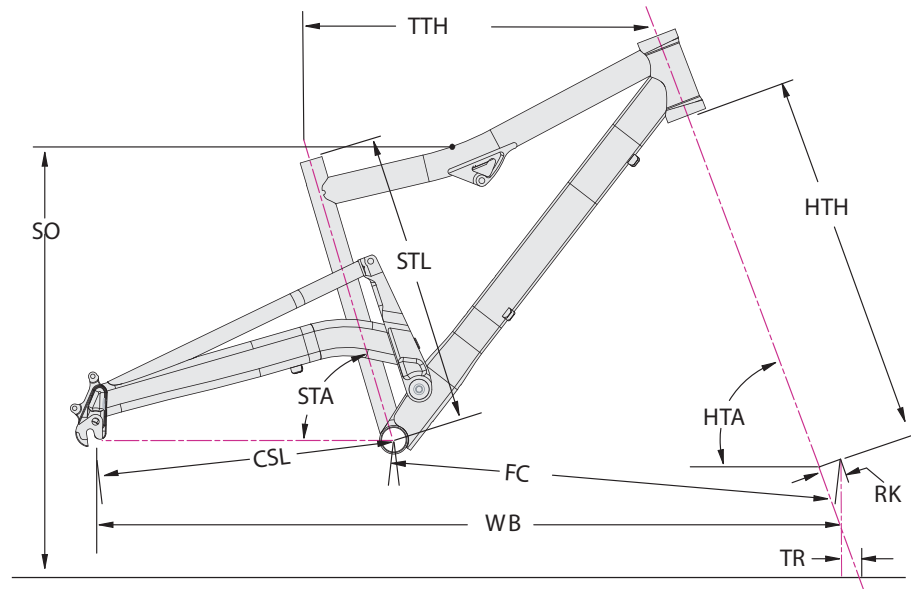
**FRAME SPECIFICATION**

ITEM	SPECIFICATION
MODEL	RUSH ALLOY
Frame material	6061-t6, tig welded, aluminum alloy
Sizes	S, M, L, X
Maximum tire width	2.3"
Head tube	Headshok, OnePointFive
Maximum fork length	500mm
Seat post diameter	27.2 ±0.1mm
Rear shock bushing width (frame mount)	32.4 ±0.1mm
Rear shock bushing width (swingarm)	37.4 ±0.1mm
Bolt diameter	8.1 ±0.5mm
Rear shock eyelet-to-eyelet length	190 mm (7.5")
Rear wheel travel	110mm
Rear shock stroke length	45mm
Rear shock leverage ratio	3:1 regressive
Front derailleur	Bottom pull top swing 31.8mm
Bottom bracket shell (width, thread type)	68mm, English /SI Hollowgram
Chain line	47.5mm
Dropout spacing	135mm
Rear hub spacing	135mm
Rear axle	Quick release
Rear brake mount	International standard, 6"

**GEOMETRY**

ITEM	REF	SMALL	MEDIUM	LARGE	X-LARGE
Seat tube angle (degree)	STA	73.5°	73.5°	73.5°	73.5°
Head tube angle (degree)	HTA	69°	69°	69°	69°
Horizontal top tube (cm)	TTH	57.5	60	62.5	65
Seat tube length (cm)	STL	40.5	43	48	50
Chainstay length (cm)	CSL	42.15	42.15	42.15	42.15
Bottom bracket height (cm)	BBH	32	32	32	32
Wheelbase (cm)	WB	107.5	110.2	113.1	115.8
Trail (cm)	TR	5.8	5.8	5.8	5.8
Stand over height (cm)	SO	75.4	75.2	74.5	74.5
Bottom bracket drop (cm)	BBD	1	1	1	1
Front-center distance (cm)	FC	63.5	67.1	70.4	72.6
Fork rake (cm)	RK	4.6	4.6	4.6	4.6

\* All dimensions: suspension fully extended.

# MARATHON



## RUSH 4

Frame	▽	Rush 110mm
Fork	┌	Lefty Speed 110 DLR2
Rear Shock	▬	Fox Float RPL Air
Rims	○	Mavic XM317 Disc, 32 hole
Hubs	⊕	Cannondale Lefty front, DT Swiss XC rear
Spokes	✱	DT Swiss Champion
Tires	▨	Hutchinson Piranha, 26 x 2.0"
Pedals	⊕	crankbrothers candy c
Crank	⊕	FSA V-drive MegaExo, 22/32/44
Bottom Bracket	⊕	FSA MegaExo
Chain	○	Shimano HG-53
Rear Cogs	≡	SRAM PG-950, 11-34
Front Derailleur	≡	Shimano LX
Rear Derailleur	≡	Shimano XT
Shifters	⊕	Shimano LX RAPIDFIRE plus
Handlebar	┌	FSA XC-282-AOS, 25mm rise
Stem	┌	Cannondale XC3 Headshok 31.8mm
Headset	⊕	Cannondale Headshok Si
Brakes	≡	Shimano LX w/ 160mm rotors
Brake Levers	┌	Shimano LX
Saddle	┌	Fi'zi:k Nisene Sport
Seatpost	┌	Cannondale Fire, 27.2 x 350mm
Sizes	▬	S,M,L,X
Color Code	┌	Charcoal Grey (gloss) (GRY) Tangerine (gloss) (ORG)
Extra's	...!	Cannondale V-Tech grips



Charcoal Grey (gloss) (GRY)



RUSH 5



Team Replica (gloss) (REP)

Frame	△	Rush 110mm
Fork	∩	Lefty Speed 110 DLR2
Rear Shock	⊞	Fox Float RP2 Air
Rims	○	Mavic XM117 Disc, 32 hole
Hubs	⊞	Cannondale Lefty front, Shimano M475 rear
Spokes	✱	DT Swiss Champion
Tires	⊞	Hutchinson Spider, 26 x 2.0"
Pedals	⊞	New Welgo Clipless, 117543
Crank	⊞	FSA Alpha Drive, 22/32/44
Bottom Bracket	⊞	FSA ISIS SL
Chain	○	Shimano HG-53
Rear Cogs	≡	SRAM PG-950, 11-34
Front Derailleur	≡	Shimano LX
Rear Derailleur	≡	SRAM X-9
Shifters	⊞	SRAM X-7 Trigger
Handlebar	∩	Cannondale Fire, 20mm rise
Stem	⊞	Cannondale XC3 Headshok 25.4mm
Headset	⊞	Cannondale Headshok Si
Brakes	⊞	Avid Juicy 3 w/ 160mm rotors
Brake Levers	∩	Avid Juicy 3
Saddle	∩	Cannondale XC
Seatpost	∩	FSA SP-FR-270, 27.2 x 350mm
Sizes	≡	S,M,L,X
Color Code	∩	Lightning White (gloss) (WHT) Team Replica (gloss) (REP)
Extra's	...!	Cannondale V-Tech grips
Notes:		

# MARATHON



## RUSH 6

Frame	▽	Rush 110mm
Fork	┌	RockShox Recon 327 Solo Air
Rear Shock	⊞	Manitou Radium R Air
Rims	○	Mach 1 2.30, 32 hole
Hubs	⊞	Shimano M475
Spokes	✱	DT Swiss Champion
Tires	⋈	Hutchinson Spider, 26 x 2.0"
Pedals	⊞	Wellgo alloy cage w/ clip and strap
Crank	⊞	Truvativ IsoFlow, 22/32/44
Bottom Bracket	⊞	Shimano BB-UN26
Chain	○	Shimano HG-53
Rear Cogs	≡	SRAM PG-950, 11-34
Front Derailleur	≡	Shimano Deore
Rear Derailleur	≡	SRAM X-7
Shifters	⊞	SRAM SX-5 Trigger
Handlebar	┌	Cannondale Fire, 20mm rise
Stem	┌	Cannondale XC3 Headshok 25.4mm
Headset	⊞	FSA Orbit DL 1-1/8"
Brakes	⊞	Avid Juicy 3 w/ 160mm rotors
Brake Levers	┌	Avid Juicy 3
Saddle	┌	Cannondale XC
Seatpost	┌	Cannondale C4, 27.2 x 350mm
Sizes	≡	S,M,L,X
Color Code	┌	Fine Silver (gloss) (SLV) Patriot Blue (gloss) (BLU)
Extra's	...!	Cannondale V-Tech grips



Fine Silver (gloss) (SLV)



SCALPEL  Caffeina.

# X-C RACING

## XC RACING



## SCALPEL

### ► Moulded carbon fiber seat stays further reduce weight.

- DE Durch die gegossenen Carbon-Sitzstreben reduziert sich das Gewicht nochmals.
- ES Tirantes de carbono moldeado para rebajar aun más el peso.
- IT I foderi alti formati in fibra di carbonio riducono ulteriormente il peso.
- FR Les haubans en fibres de carbone moulés permettent de gagner encore en légèreté.
- NL Gegoten carbonfiber staande achtervorken verlagen het gewicht.

### ►► Pivotless chainstays, nearly weightless, yet delivering 69mm of travel.

- DE Kettenstreben ohne Gelenk, nahezu ohne Gewicht, aber als Basis für 69 mm Federweg.
- ES Las ligerísimas vainas sin pivote proporcionan 69 mm de recorrido trasero.
- IT Foderi bassi privi di fulcro, praticamente senza peso, forniscono 69mm di escursione.
- FR Bases arrière sans pivot, extrêmement légères, et avec un débattement de 69 mm.
- NL Liggende achtervork zonder draaipunt, bijna gewichtloos, en toch 69mm veerweg.

### ►►► World cup proven chassis, The benchmark full suspension xc race bike.

- DE Dieses Worldcup-erprobte Chassis ist der Maßstab, an dem sich alle vollgefederten Crosscountry-Rennmaschinen zu messen haben.
- ES Cuadro probado en la Copa del mundo. La bicicleta a batir en el circuito de XC profesional.
- IT Telaio provato nella Coppa del Mondo, il riferimento biammortizzato nelle gare di XC.
- FR Cadre éprouvé en Coupe du Monde, la référence en vélo de compétition XC tout suspens.
- NL Chassis heeft zich bewezen in World cup races. Dé maatstaf voor full suspension xc race bikes.

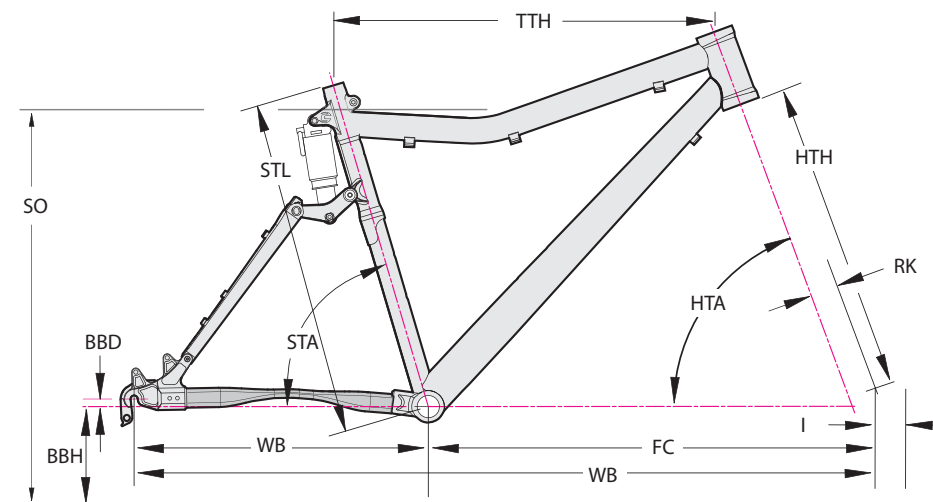

**FRAME SPECIFICATION**

ITEM	SPECIFICATION	
MODEL	SCALPEL	SCALPEL SI
Frame material	6061 T6, TIG Welded Aluminum Alloy	
Sizes	S, M, L, XL	
Recommended sag	25%	
Maximum tire width	53.3mm, 2.1 in	
Headtube	HEADSHOK, OnePointFive	
Headtube height	114 mm	
Maximum fork length	500mm	
Seatpost diameter	27.2mm	
Bolt hole diameter	6mm	
Rear shock bushing width upper	16mm	
Rear shock bushing width lower	22mm	
Rear shock eye-to-eye length	139.7mm	
Rear wheel travel	67mm	
Rear shock stroke length	25.4mm	
Rear shock leverage ratio	2.7:1	
Front derailleur	31.8 Bottom Pull Top, traditional swing	
Bottom bracket shell thread type	68mm, English	SI Hollowgram
Chain line	47.5mm	
Dropout spacing*	135mm	
Rear hub spacing	135mm	
Rear hub axle	Quick release	
Rear brake mount	International Standard 6" only	

**GEOMETRY**

ITEM	REF	SMALL	MEDIUM	LARGE	X-LARGE
Seat tube angle (degree)	STA	73.5	73.5	73.5	73.5
Head tube angle (degree)	HTA	70	70	70	70
Horizontal top tube (cm)	TTH	55.9	59.7	62.2	64.8
Seat tube length (cm)	STL	47	47	55.9	55.9
Chainstay length (cm)	CSL	43.4	43.4	43.4	43.4
Bottom bracket height (cm)	BBH	31.8	31.8	31.8	31.8
Wheelbase (cm)	WB	106.2	110	113.1	115.6
Trail (cm)	TR	7.1	7.1	7.1	7.1
Stand over height (cm)	SO	71.4	73.7	77	79.2
Bottom bracket drop (cm)	BBD	1.1	1.1	1.1	1.1
Front-center distance (cm)	FC	63.5	67.1	70.4	72.6
Fork rake (cm)	RK	4.6	4.6	4.6	4.6

\* All dimensions: suspension fully extended.

## XC RACING



### SCALPEL TEAM REPLICA

Frame	▽	Scalpel Si 67mm
Fork	┆	Lefty Speed Carbon SL 110 DLR2
Rear Shock	▢	Fox Float RPL Air
Rims	○	Mavic CrossMax SLR UST
Hubs	┆	Mavic CrossMax SLR
Spokes	✱	New Mavic X-Max SLR
Tires	▨	Maxxis Larsen TT UST, 26 x 2.0"
Pedals	▢	N/A
Crank	⊕	Cannondale Hollowgram Si, 22/32/44
Bottom Bracket	┆	Cannondale Si
Chain	○	SRAM 991
Rear Cogs	▢	SRAM PG-990, 11-32
Front Derailleur	┆	Shimano XTR
Rear Derailleur	┆	SRAM X-0
Shifters	⊕	SRAM X-0 Trigger
Handlebar	┆	FSA K-Force Carbon Flat
Stem	┆	Cannondale Si one piece Stem/Steerer 31.8mm
Headset	⊕	Cannondale Headshok Si
Brakes	┆	Avid Juicy Ultimate w/ 140mm rotors
Brake Levers	┆	Avid Juicy Ultimate
Saddle	┆	Fi'zi:k Gobi w/ Ti rails
Seatpost	┆	FSA K Force Lite Carbon SB-25, 27.2 x 350mm
Sizes	▢	S,M,L,X
Color Code	┆	Team Replica (gloss) (REP)
Extra's	...!	Cannondale V-Tech grips

Notes:

**cannondale**  
FEEL IT.

© Cannondale Bicycle Corp. V3 7/06. All prices and specifications subject to change without notice. • Orders subject to approval at our European headquarters.



## SCALPEL 1

Frame	△	Scalpel 67mm
Fork	∩	Lefty Speed Carbon SL 110 DLR2
Rear Shock	⊞	Fox Float RPL Air
Rims	○	Mavic CrossMax SLR UST
Hubs	⊞	Mavic CrossMax SLR
Spokes	✱	New Mavic X-Max SLR
Tires	⊞	Maxxis Larsen TT UST, 26 x 2.0"
Pedals	⊞	crankbrothers egg beater c
Crank	⊞	Shimano XTR, 22/32/44
Bottom Bracket	⊞	Shimano XTR
Chain	○	Shimano CN-7701
Rear Cogs	≡	Shimano XTR, 11-34
Front Derailleur	≡	Shimano XTR
Rear Derailleur	≡	Shimano XTR
Shifters	⊞	Shimano XTR RAPIDFIRE plus
Handlebar	∩	FSA K-Force Carbon Flat
Stem	∩	Cannondale Si one piece Stem/Steerer 31.8mm
Headset	⊞	Cannondale Headshok Si
Brakes	⊞	Shimano XTR w/ 160mm rotors
Brake Levers	∩	Shimano XTR
Saddle	∩	Fi'zi:k Gobi w/ Ti rails
Seatpost	∩	FSA K Force Lite Carbon SB-25, 27.2 x 350mm
Sizes	≡	S,M,L,X
Color Code	∩	Jet Black (gloss) (BLK)
Extra's	...!	Cannondale V-Tech grips
Notes:		

## XC RACING



### SCALPEL 2

Frame	∇	Scalpel 67mm
Fork	∩	Lefty Speed Carbon 110 DLR2
Rear Shock	⊞	Fox Float RPL Air
Rims	○	Mavic XM819 Disc UST, 24 hole
Hubs	⊞	Cannondale Lefty front, Sun Ringle Dirty Flea rear
Spokes	✱	DT Swiss Super Comp
Tires	⋯	Maxxis Larsen TT UST, 26 x 2.0"
Pedals	⊞	crankbrothers egg beater c
Crank	⊞	Shimano XT, 22/32/44
Bottom Bracket	⊞	Shimano XT
Chain	○	Shimano HG-73
Rear Cogs	≡	Shimano XT, 11-34
Front Derailleur	≡	Shimano XT
Rear Derailleur	≡	Shimano XT
Shifters	⊞	Shimano XT RAPIDFIRE plus
Handlebar	∩	ControlTech Carbon Flat
Stem	⊞	Cannondale Si one piece Stem/Steerer 31.8mm
Headset	⊞	Cannondale Headshok Si
Brakes	⊞	Avid Juicy 7 w/ 160mm rotors
Brake Levers	∩	Avid Juicy 7
Saddle	∩	Fi'zi:k Gobi w/ Ti rails
Seatpost	∩	ControlTech Carbon, 27.2 x 350mm
Sizes	≡	S,M,L,X
Color Code	∩	Patriot Blue (gloss) (BLU)
Extra's	⋯	Cannondale V-Tech grips

Notes:



## SCALPEL 3

Frame	∇	Scalpel 67mm
Fork	∩	Lefty Speed 110 DLR2
Rear Shock	⊞	Fox Float RPL Air
Rims	○	Mavic XM819 Disc UST, 24 hole
Hubs	⊞	Cannondale Lefty front, DT Swiss XC rear
Spokes	✱	DT Swiss Competition
Tires	⊞	Maxxis Larsen TT UST, 26 x 2.0"
Pedals	⊞	crankbrothers egg beater c
Crank	⊞	FSA Afterburner MegaExo, 22/32/44
Bottom Bracket	⊞	FSA MegaExo
Chain	○	SRAM 951
Rear Cogs	≡	SRAM PG-970, 11-34
Front Derailleur	≡	Shimano LX
Rear Derailleur	≡	SRAM X-9
Shifters	⊞	SRAM X-7 Trigger
Handlebar	∩	Cannondale C2 Flat
Stem	∩	Cannondale Si one piece Stem/Steerer 31.8mm
Headset	⊞	Cannondale Headshok Si
Brakes	⊞	Avid Juicy 7 w/ 160mm rotors
Brake Levers	∩	Avid Juicy 7
Saddle	∩	Fi'zi:k Nisene Sport
Seatpost	∩	Cannondale Fire Carbon, 27.2 x 350mm
Sizes	≡	S,M,L,X
Color Code	∩	Team Replica (gloss) (REP)
Extra's	...!	Cannondale V-Tech grips

Notes:

---



---



---



---

## XC RACING



### SCALPEL 4

Frame		Scalpel 67mm
Fork		HeadShok Super Fatty Ultra 80 DLR
Rear Shock		Fox Float RP3 Air
Rims		Mavic XM317 Disc, 32 hole
Hubs		DT Swiss XC
Spokes		DT Swiss Champion
Tires		Hutchinson Piranha, 26 x 2.0"
Pedals		crankbrothers egg beater c
Crank		FSA V-drive MegaExo, 22/32/44
Bottom Bracket		FSA MegaExo
Chain		Shimano HG-53
Rear Cogs		SRAM PG-950, 11-34
Front Derailleur		Shimano LX
Rear Derailleur		Shimano XT
Shifters		Shimano LX RAPIDFIRE plus
Handlebar		Cannondale C2 Flat
Stem		Cannondale XC3 Headshok 25.4mm
Headset		Cannondale Headshok Si
Brakes		Shimano LX w/ 160mm rotors
Brake Levers		Shimano LX
Saddle		Fi'zi:k Nisene Sport
Seatpost		Cannondale C3 16mm offset, 27.2 x 350mm
Sizes		S,M,L,X
Color Code		Race Red (gloss) (RED) Lightning White (gloss) (WHT)
Extra's		Cannondale V-Tech grips
Notes:		



Color (code) Race Red (gloss) (RED)



SCALPEL 5



Team Replica (gloss) (REP)

Frame	∇	Scalpel 67mm
Fork	∩	HeadShok Super Fatty Ultra 80 DLR
Rear Shock	⊞	Fox Float R Air
Rims	○	Mavic XM117 Disc, 32 hole
Hubs	⊞	Formula DC-94 front, DC-58 rear
Spokes	✱	DT Swiss Champion
Tires	⊞	Hutchinson Piranha, 26 x 2.0"
Pedals	⊞	Welgo Clipless
Crank	⊞	FSA V-drive MegaExo, 22/32/44
Bottom Bracket	⊞	FSA MegaExo
Chain	○	Shimano HG-53
Rear Cogs	≡	SRAM PG-950, 11-34
Front Derailleur	≡	Shimano LX
Rear Derailleur	≡	SRAM X-9
Shifters	⊞	SRAM X-7 Trigger
Handlebar	∩	Cannondale C2 Flat
Stem	∩	Cannondale XC3 Headshok 25.4mm
Headset	⊞	Cannondale Headshok Si
Brakes	⊞	Avid Juicy 5 w/ 160mm rotors
Brake Levers	∩	Avid Juicy 5
Saddle	∩	Fi'zi:k Nisene Sport
Seatpost	∩	FSA SP-FR-270, 27.2 x 350mm
Sizes	≡	S,M,L,X
Color Code	∩	Team Replica (gloss) (REP) Jet Black (gloss) (BLK)
Extra's	...!	Cannondale V-Tech grips
Notes:		

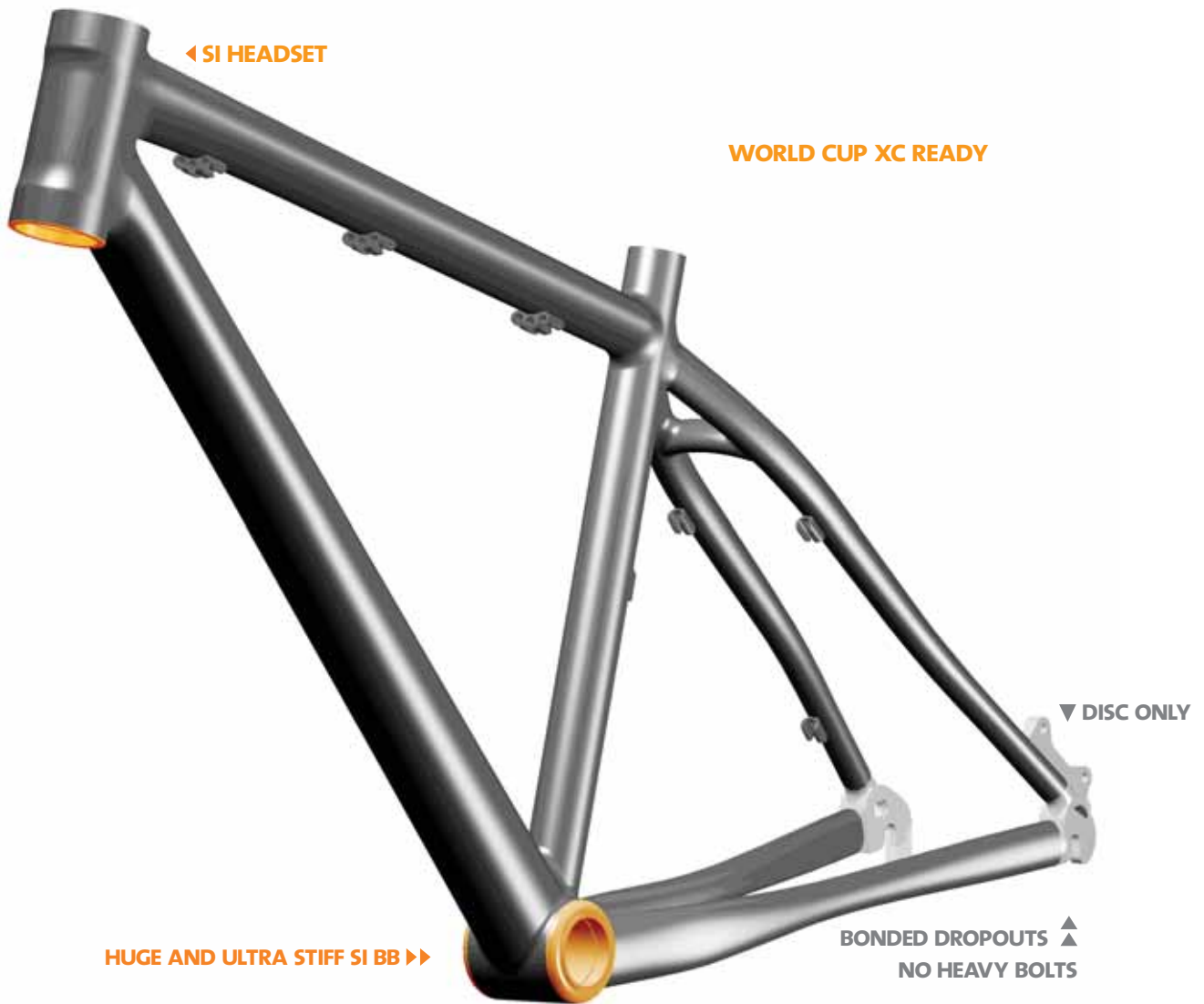

## TAURINE

► By installing the Headset bearings directly into the frame even more weight was saved on this rocket ship.

DE Durch die Montage der Steuersatzlager direkt in die Rahmenrohre konnte bei dieser Rennrakete nochmals Gewicht gespart werden.

ES La dirección sin cazoletas reduce aún más el peso de este bólido de competición.

IT Installando i cuscinetti della serie sterzo direttamente nel telaio, siamo riusciti ad alleggerire ulteriormente questo razzo.

FR Le montage du roulement de direction directement sur le cadre a permis de gagner encore plus de poids sur cette bête de course.

NL Door de Headset-lagers direct in het frame te monteren, werd nog meer gewicht bespaard op deze race-raket.

►► World cup XC ready, Carbon frame optimized for stiffness and a smooth ride.

DE Bereit für den CC-Worldcup. Der Carbon-Rahmen ist steif und sanft zugleich.

ES Puesta a prueba en la copa del mundo. Cuadro de carbono optimizado para incrementar la rigidez y garantizar una conducción suave.

IT Pronto per la Coppa del Mondo XC, il telaio Carbon è ottimizzato per la rigidità e per un ottimo assorbimento delle vibrazioni.

FR Prêt pour la coupe du Monde XC. Cadre carbone optimisé pour la rigidité et le confort.

NL Klaar voor de Worldcup XC, Carbon frame geoptimaliseerd voor stijfheid versus soepel rijden.

►►► Huge and ultra stiff Si BB shell transmits all pedaled energy into forward motion.

DE Das große und ultrasteife Tretlagergehäuse setzt die Pedalkraft verlustfrei in Vorwärtsbewegung um.

ES La enorme caja del eje transmite toda la energía transformándola en movimiento.

IT Una scatola del movimento centrale enorme ed ultra rigida trasforma tutta l'energia della pedalata in spinta.

FR Grâce à son boîtier de pédalier surdimensionné et extrêmement rigide, toute l'énergie est transformée en mouvement.

NL Groot en ultrastijf trapaslager zet alle pedaalkracht direct om in voorwaartse beweging.

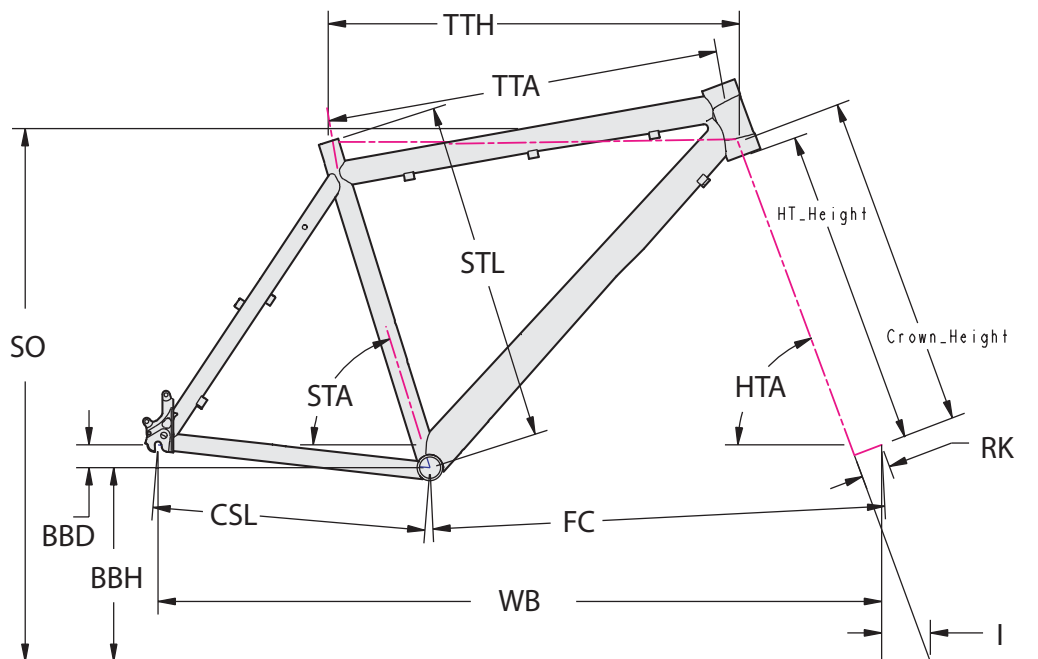

**FRAME SPECIFICATION**

**GEOMETRY**

ITEM	SPECIFICATION
MODEL	TAURINE
Frame material	Carbon fiber
Sizes	S, M, L, X
Seatpost Diameter	31.6mm
Headtube	Cannondale System Integration
Bottom Bracket	Cannondale System Integration
Dropout Spacing	135mm
Hub Spacing	135mm
Front Derailleur	34.9mm clamp-on
Rear Brake Mount	International Standard, 6"

ITEM	REF	SMALL	MEDIUM	LARGE	X-LARGE
Seat tube angle (degree)	STL	74.25	73.5	73	72.5
Head tube angle (degree)	HTA	70	70	70	70
Horizontal top tube (cm)	TTH	55.5	59.1	61.6	63.5
Seat tube length (cm)	STL	38	43.3	47.5	52.5
Chainstay length (cm)	CSL	42.4	42.4	42.4	42.4
Bottom bracket height (cm)	BBH	29.8	29.8	29.8	29.8
Bottom bracket drop	BBD	3.5	3.5	3.5	3.5
Wheelbase (cm)	WB	104.3	108.3	110.6	111.6
Stand over height (cm)	SO	76.5	78.5	80.5	81.5
Front-center distance (cm)	FC	62.1	66.1	68.5	69.4
Fork rake (cm)	RK	4.5	4.5	4.5	4.5
Trail (cm)	TR	7.3	7.3	7.3	7.3

## XC RACING



### TAURINE SL TEAM REPLICA

Frame	▽	Taurine Carbon Si
Fork	┆	Lefty Speed Carbon SL 110 DLR2
Rear Shock	▬	N/A
Rims	○	Mavic CrossMax SLR UST
Hubs	⊕	Mavic CrossMax SLR
Spokes	✱	New Mavic X-Max SLR
Tires	⋈	Maxxis Larsen TT UST, 26 x 2.0"
Pedals	⊕	N/A
Crank	⊕	Cannondale Hollowgram Si, 22/32/44
Bottom Bracket	⊕	Cannondale Si
Chain	○	SRAM 991
Rear Cogs	≡	SRAM PG-990, 11-32
Front Derailleur	≡	Shimano XTR
Rear Derailleur	≡	SRAM X-0
Shifters	⊕	SRAM X-0 Trigger
Handlebar	┆	FSA K-Force Carbon Flat
Stem	┆	Cannondale Si one piece Stem/Steerer 31.8mm
Headset	⊕	Cannondale Headshok Si
Brakes	≡	Avid Juicy Ultimate w/ 160/140mm rotors
Brake Levers	┆	Avid Juicy Ultimate
Saddle	┆	Fi'zi:k Gobi w/ Ti rails
Seatpost	┆	FSA K-Force Lite Carbon SB-25, 31.6 x 350mm
Sizes	≡	S,M,L,X
Color Code	┆	Team Replica (gloss) (REP)
Extra's	...!	Cannondale V-Tech grips

Notes:



TAURINE 1 SL

























Lightning White (gloss) (WHT)

Frame	△	Taurine Carbon Si
Fork	∩	HeadShok Super Fatty Ultra 80 DLR
Rear Shock	⊞	N/A
Rims	○	Mavic CrossMax SLR UST
Hubs	⊕	Mavic CrossMax SLR
Spokes	✱	New Mavic X-Max SLR
Tires	⊞	Maxxis Larsen TT UST, 26 x 2.0"
Pedals	⊞	crankbrothers egg beater c
Crank	⊕	Shimano XTR, 22/32/44
Bottom Bracket	⊞	Shimano XTR
Chain	○	Shimano CN-7701
Rear Cogs	≡	Shimano XTR, 11-34
Front Derailleur	∩	Shimano XTR
Rear Derailleur	∩	Shimano XTR
Shifters	⊕	Shimano XTR RAPIDFIRE plus
Handlebar	∩	FSA K-Force Carbon Flat
Stem	∩	Cannondale XC3 Headshok 31.8mm
Headset	⊕	Cannondale Headshok Si
Brakes	∩	Shimano XTR w/ 160mm rotors
Brake Levers	∩	Shimano XTR
Saddle	∩	Fi'zi:k Gobi w/ Ti rails
Seatpost	∩	FSA K Force Lite Carbon SB-25, 31.6 x 350mm
Sizes	∩	S,M,L,X
Color Code	∩	Team Replica (gloss) (REP) Lightning White (gloss) (WHT)
Extra's	...!	Cannondale V-Tech grips
Notes:		

## XC RACING



## TAURINE 2 SL

Frame		Taurine Carbon Si
Fork		HeadShok Super Fatty Ultra 80 DLR
Rear Shock		N/A
Rims		Mavic XM819 Disc UST, 24 hole
Hubs		Sun Ringle Dirty Flea
Spokes		DT Swiss Super Comp
Tires		Maxxis Larsen TT UST, 26 x 2.0"
Pedals		crankbrothers egg beater c
Crank		Cannondale Carbon Si 2-piece, 22/32/44
Bottom Bracket		Cannondale Si
Chain		Shimano HG-73
Rear Cogs		Shimano XT, 11-34
Front Derailleur		Shimano XT
Rear Derailleur		Shimano XT
Shifters		Shimano XT RAPIDFIRE plus
Handlebar		ControlTech Carbon Flat
Stem		Cannondale XC3 Headshok 25.4mm
Headset		Cannondale Headshok Si
Brakes		Avid Juicy 7 w/ 160mm rotors
Brake Levers		Avid Juicy 7
Saddle		Fi'zi:k Nisene HP w/ Ti rails
Seatpost		FSA SL-K Carbon, 31.6 x 350mm
Sizes		S,M,L,X
Color Code		Team Replica (gloss) (REP) Lightning White (gloss) (WHT)
Extra's		Cannondale V-Tech grips
Notes:		



Lightning White (gloss) (WHT)



TAURINE 3 SL



Team Replica (gloss) (REP)

Frame	▽	Taurine Carbon Si
Fork	┆	HeadShok Super Fatty Ultra 80 DLR
Rear Shock	▣	N/A
Rims	○	Mavic XM819 Disc UST, 24 hole
Hubs	┆	DT Swiss XC
Spokes	✱	DT Swiss Competition
Tires	⋯	Maxxis Larsen TT UST, 26 x 2.0"
Pedals	▣	crankbrothers egg beater c
Crank	⊕	FSA Afterburner MegaExo, 22/32/44
Bottom Bracket	┆	FSA MegaExo
Chain	○	SRAM 951
Rear Cogs	▸	SRAM PG-970, 11-34
Front Derailleur	┆	Shimano LX
Rear Derailleur	⋈	SRAM X-9
Shifters	⊕	SRAM X-7 Trigger
Handlebar	┆	Cannondale C2 Flat
Stem	┆	Cannondale XC3 Headshok 25.4mm
Headset	⊕	Cannondale Headshok Si
Brakes	⋈	Avid Juicy 7 w/ 160mm rotors
Brake Levers	┆	Avid Juicy 7
Saddle	▾	Fi'zi:k Nisene Sport
Seatpost	┆	Cannondale C3 16mm offset, 31.6 x 350mm
Sizes	▣	S,M,L,X
Color Code	┆	Team Replica (gloss) (REP) Lightning White (gloss) (WHT)
Extra's	...!	Cannondale V-Tech grips
Notes:		

## XC RACING

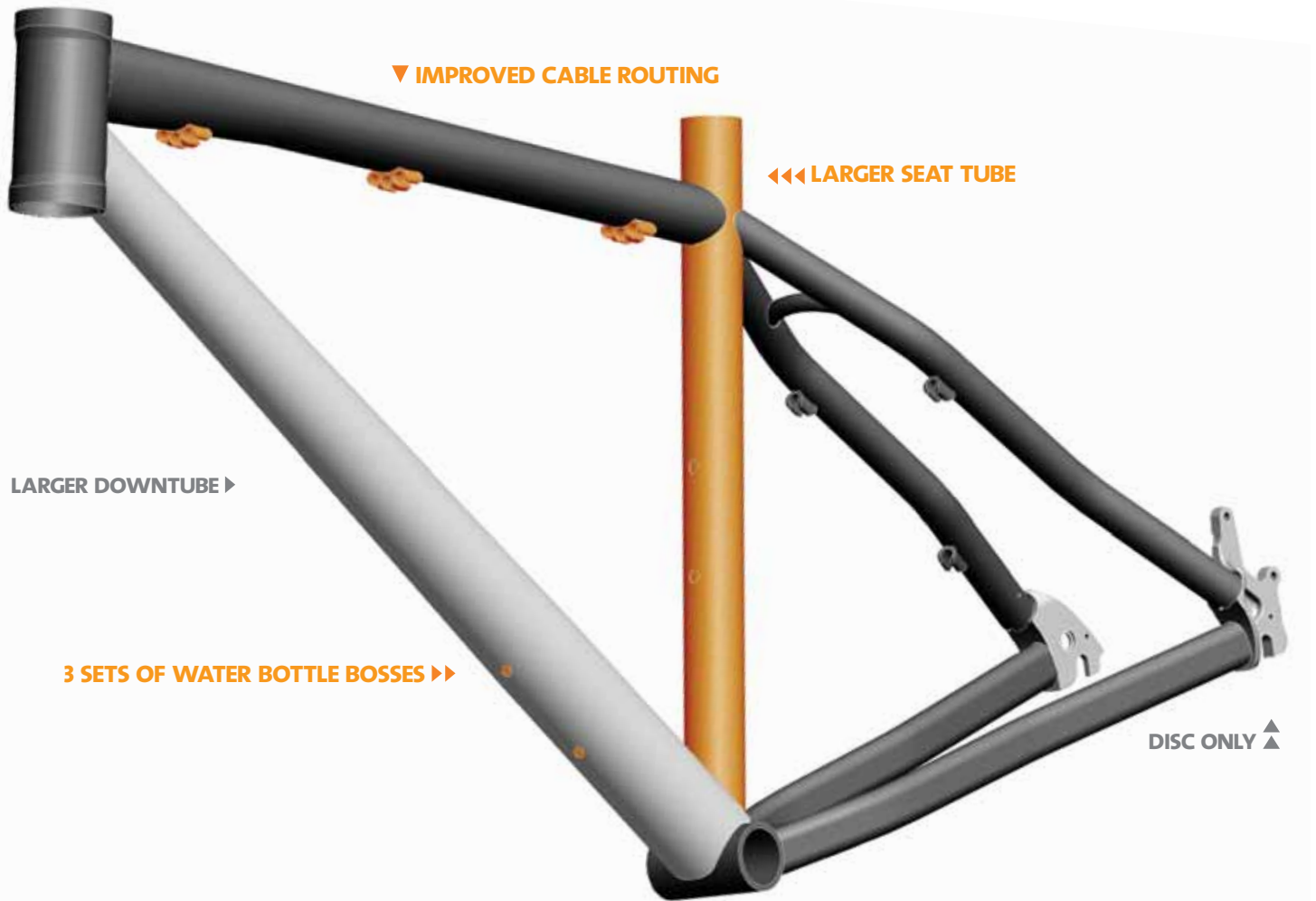

## CAFFEINE

### ► Improved, mud friendly top tube cable routing.

- DE Verbesserte und schlammresistente Kabelführung am Oberrohr.
- ES Nuevo cableado en el tubo horizontal, lejos del alcance del barro.
- IT Passaggio dei cavi nel tubo orizzontale migliorato, "fangofriendly".
- FR Passages de câbles améliorés, assurant une bonne protection contre la boue.
- NL Verbeterde, 'moddervriendelijke' kabelvoering langs de bovenbuis.

### ►► Three sets of water bottle bosses.

- DE Sockel für drei Flaschenhalter.
- ES Tres puntos de anclaje para portabidones.
- IT Tre predisposizioni per le borracce.
- FR Trois attaches porte-bidons.
- NL Drie bevestigingspunten voor bidonhouders.

### ►►► Larger diameter seat tube is stiffer, allowing all pedaling force to be transmitted to the wheel, not lost through side to side flexing.

- DE Steiferes Sitzrohr durch vergrößerten Durchmesser. Dadurch wird die Pedalkraft vollständig zum Hinterrad übertragen und geht nicht durch seitliches Ausweichen des Hinterbaus verloren.
- ES Grueso tubo vertical más rígido para lograr que toda la potencia del pedaleo se transmita a la rueda en lugar de flexionar lateralmente el cuadro.
- IT Il tubo sella a diametro più largo è più rigido per trasmettere tutta la potenza della pedalata alla ruota ed evitare che si disperda in flessibilità laterale.
- FR Tube de selle de plus grand diamètre plus rigide, pour transmettre toute la force de pédalage à la roue, sans perte par effet de flexion latérale.
- NL Vergrote diameter van de zitbuis zorgt voor meer stijfheid, waardoor alle aandrijfkraft via de pedalen naar het wiel gaat, en geen verlies door zijdelingse flex optreedt.

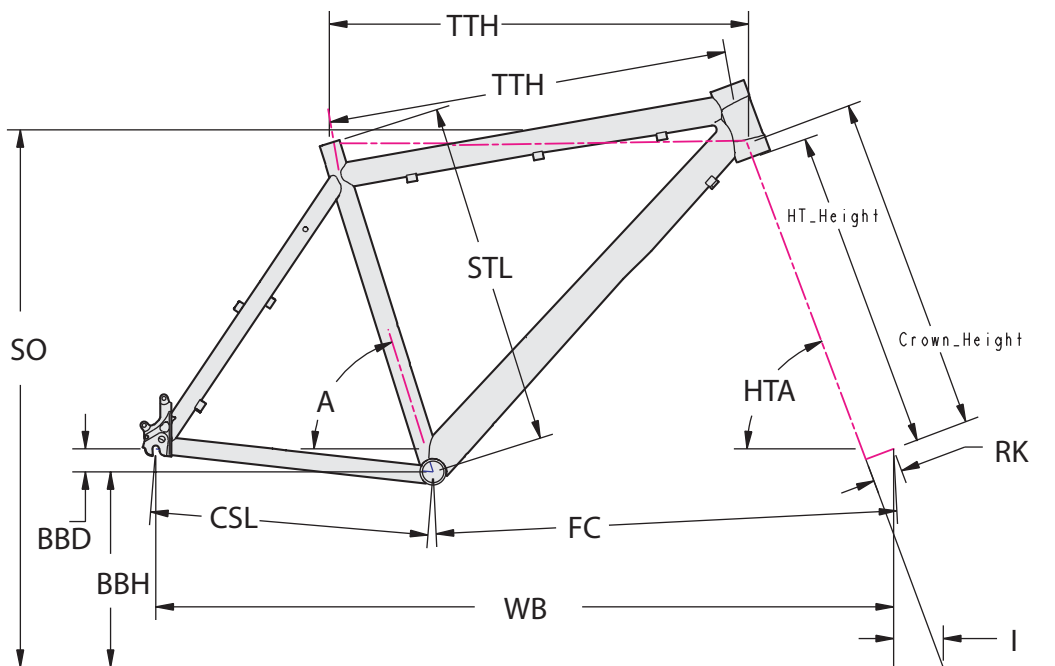

**FRAME SPECIFICATION**

**GEOMETRY**

ITEM	SPECIFICATION
MODEL	CAFFEINE
Frame	6061-T6, Tig welded, Aluminum Alloy
Sizes	S, M, L, X
Seatpost Diameter	31.6mm
Headtube	Headshok, OnePointFive
Bottom Bracket	68mm, English threaded
Dropout Spacing	135mm
Hub Spacing	135mm
Front Derailleur	34.9mm clamp-on
Rear Brake Mount	International Standard, 6"

ITEM	REF	SMALL	MEDIUM	LARGE	X-LARGE
Seat tube angle (degree)	STL	73.5	73.5	73	72.5
Head tube angle (degree)	HTA	70	70	70	70
Horizontal top tube (cm)	TTH	56.5	59.7	62.2	63.5
Horizontal top tube actual (cm)	TTA	53.1	56.1	58.9	60.9
Seat tube length (cm)	STL	38	43.3	47.5	52.5
Chainstay length (cm)	CSL	42.4	42.4	42.4	42.4
Bottom bracket height (cm)	BBH	29.8	29.8	29.8	29.8
Bottom bracket drop	BBD	3.5	3.5	3.5	3.5
Wheelbase (cm)	WB	104.9	108.2	110.6	111.7
Stand over height (cm)	SO	76.4	77.7	79.7	82
Front-center distance (cm)	FC	62.8	66.1	68.5	69.5
Head tube length (cm)	HTL	11.8	11.8	11.8	11.8
Head tube height (cm)	HTH	49	49	49	49
Fork rake (cm)	RK	4.5	4.5	4.5	4.5
Trail (cm)	TR	7.3	7.3	7.3	7.3

## XC RACING



### CAFFEINE 4 SL

Frame	▽	Caffeine
Fork	┌	HeadShok Super Fatty Ultra 80 DLR
Rear Shock	▬	N/A
Rims	○	Mavic XM317 Disc, 32 hole
Hubs	⊕	DT Swiss XC Disc
Spokes	✱	DT Swiss Champion
Tires	▨	Hutchinson Piranha, 26 x 2.0"
Pedals	⊕	crankbrothers egg beater c
Crank	⊕	FSA V-drive MegaExo, 22/32/44
Bottom Bracket	⊕	FSA MegaExo
Chain	○	Shimano HG-53
Rear Cogs	≡	SRAM PG-950, 11-34
Front Derailleur	≡	Shimano LX
Rear Derailleur	≡	Shimano XT
Shifters	⊕	Shimano LX RAPIDFIRE plus
Handlebar	┌	Cannondale C2 Flat
Stem	┌	Cannondale XC3 Headshok 25.4mm
Headset	⊕	Cannondale Headshok Si
Brakes	≡	Shimano LX w/ 160mm rotors
Brake Levers	┌	Shimano LX
Saddle	┌	Fi'zi:k Nisene Sport
Seatpost	┌	Cannondale C3 16mm offset, 31.6 x 350mm
Sizes	▬	S,M,L,X
Color Code	┌	Team Replica (gloss) (REP) Jet Black (gloss) (BLK)
Extra's	...!	Cannondale V-Tech grips
Notes:		



Team Replica (gloss) (REP)



CAFFEINE 5 SL



Jet Black (gloss) (BLK)

Frame	∇	Caffeine
Fork	∩	HeadShok Super Fatty Ultra 80 DLR
Rear Shock	⊞	N/A
Rims	○	Mavic XM117 Disc, 32 hole
Hubs	⊞	Shimano M475
Spokes	✱	DT Swiss Champion
Tires	⋯	Hutchinson Spider, 26 x 2.0"
Pedals	⊞	Welgo Clipless
Crank	⊞	FSA Alpha Drive, 22/32/44
Bottom Bracket	⊞	FSA ISIS SL
Chain	○	Shimano HG-53
Rear Cogs	≡	SRAM PG-950, 11-34
Front Derailleur	⌒	Shimano LX
Rear Derailleur	⌒	Shimano XT
Shifters	⊞	Shimano Deore RAPIDFIRE plus
Handlebar	∩	Cannondale C2 Flat
Stem	⊞	Cannondale XC3 Headshok 25.4mm
Headset	⊞	Cannondale Headshok Si
Brakes	⊞	Avid Juicy 3 w/ 160mm rotors
Brake Levers	∩	Avid Juicy 3
Saddle	∩	Cannondale 71 All Mountain
Seatpost	∩	FSA SP-FR-270, 31.6 x 350mm
Sizes	⊞	S,M,L,X
Color Code	∩	Patriot Blue (gloss) (BLU) Jet Black (gloss) (BLK)
Extra's	...!	Cannondale V-Tech grips
Notes:		



*Caffeine.* FURIO X

**X-C**

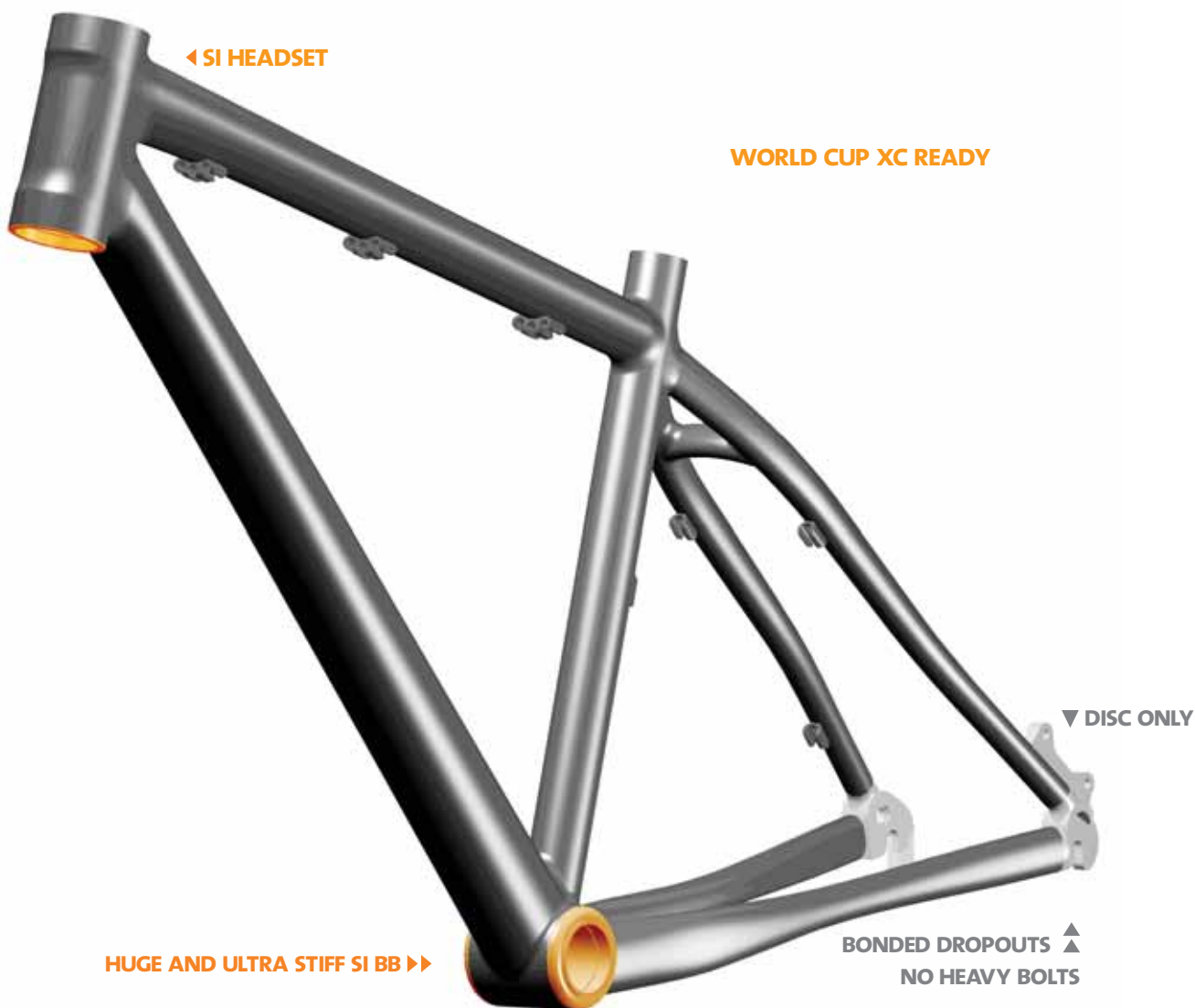

## TAURINE

► By installing the Headset bearings directly into the frame even more weight was saved on this rocket ship.

DE Durch die Montage der Steuersatzlager direkt in die Rahmenrohre konnte bei dieser Rennrakete nochmals Gewicht gespart werden.

ES La dirección sin cazoletas reduce aún más el peso de este bólido de competición.

IT Installando i cuscinetti della serie sterzo direttamente nel telaio, siamo riusciti ad alleggerire ulteriormente questo razzo.

FR Le montage du roulement de direction directement sur le cadre a permis de gagner encore plus de poids sur cette bête de course.

NL Door de Headset-lagers direct in het frame te monteren, werd nog meer gewicht bespaard op deze race-raket.

►► World cup XC ready, Carbon frame optimized for stiffness and a smooth ride.

DE Bereit für den CC-Worldcup. Der Carbon-Rahmen ist steif und sanft zugleich.

ES Puesta a prueba en la copa del mundo. Cuadro de carbono optimizado para incrementar la rigidez y garantizar una conducción suave.

IT Pronto per la Coppa del Mondo XC, il telaio Carbon è ottimizzato per la rigidità e per un ottimo assorbimento delle vibrazioni.

FR Prêt pour la coupe du Monde XC. Cadre carbone optimisé pour la rigidité et le confort.

NL Klaar voor de Worldcup XC, Carbon frame geoptimaliseerd voor stijfheid versus soepel rijden.

►►► Huge and ultra stiff Si BB shell transmits all pedaled energy into forward motion.

DE Das große und ultrasteife Tretlagergehäuse setzt die Pedalkraft verlustfrei in Vorwärtsbewegung um.

ES La enorme caja del eje transmite toda la energía transformándola en movimiento.

IT Una scatola del movimento centrale enorme ed ultra rigida trasforma tutta l'energia della pedalata in spinta.

FR Grâce à son boîtier de pédalier surdimensionné et extrêmement rigide, toute l'énergie est transformée en mouvement.

NL Groot en ultrastijf trapaslager zet alle pedaalkracht direct om in voorwaartse beweging.

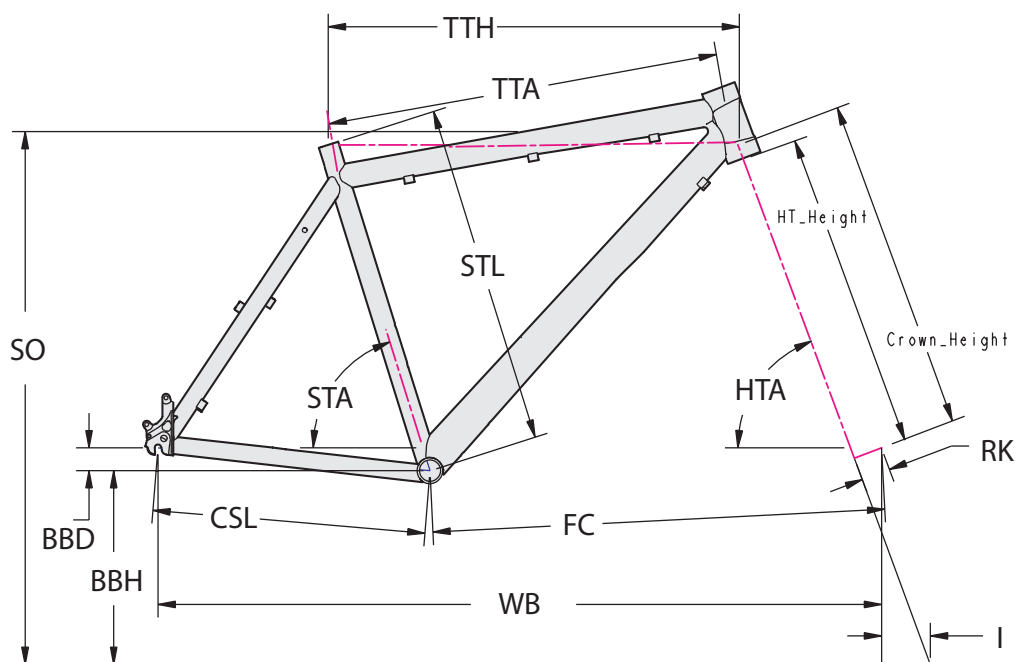

## FRAME SPECIFICATION

ITEM	SPECIFICATION
MODEL	TAURINE
Frame material	Carbon fiber
Sizes	S, M, L, X
Seatpost Diameter	31.6mm
Headtube	Cannondale System Integration
Bottom Bracket	Cannondale System Integration
Dropout Spacing	135mm
Hub Spacing	135mm
Front Derailleur	34.9mm clamp-on
Rear Brake Mount	International Standard, 6"

## GEOMETRY

ITEM	REF	SMALL	MEDIUM	LARGE	X-LARGE
Seat tube angle (degree)	STL	74.25	73.5	73	72.5
Head tube angle (degree)	HTA	70	70	70	70
Horizontal top tube (cm)	TTH	55.5	59.1	61.6	63.5
Seat tube length (cm)	STL	38	43.3	47.5	52.5
Chainstay length (cm)	CSL	42.4	42.4	42.4	42.4
Bottom bracket height (cm)	BBH	29.8	29.8	29.8	29.8
Bottom bracket drop	BBD	3.5	3.5	3.5	3.5
Wheelbase (cm)	WB	104.3	108.3	110.6	111.6
Stand over height (cm)	SO	76.5	78.5	80.5	81.5
Front-center distance (cm)	FC	62.1	66.1	68.5	69.4
Fork rake (cm)	RK	4.5	4.5	4.5	4.5
Trail (cm)	TR	7.3	7.3	7.3	7.3



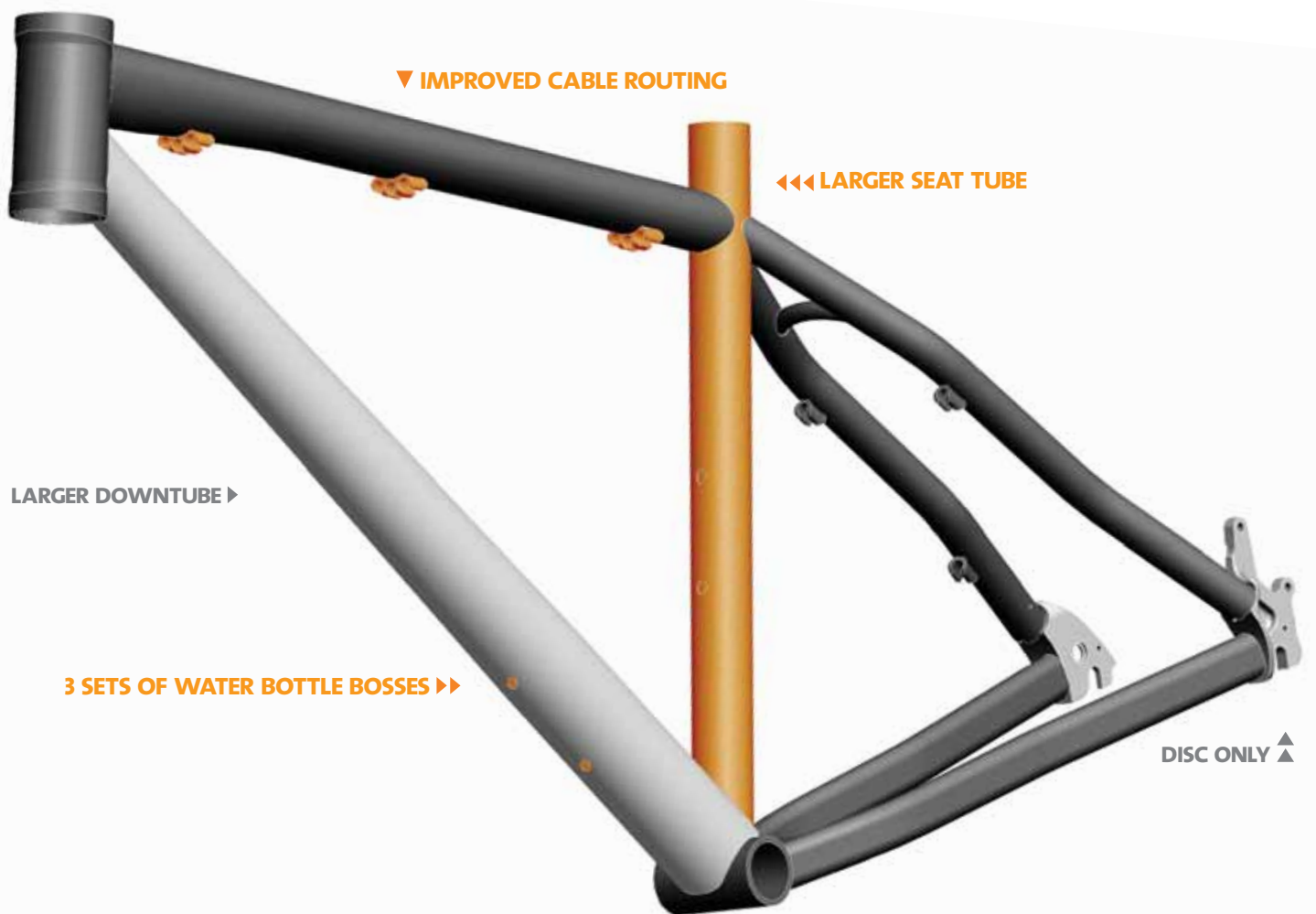

## CAFFEINE

► Improved, mud friendly top tube cable routing.

- DE Verbesserte und schlammresistente Kabelführung am Oberrohr.
- ES Nuevo cableado en el tubo horizontal, lejos del alcance del barro.
- IT Passaggio dei cavi nel tubo orizzontale migliorato, "fangofriendly".
- FR Passages de câbles améliorés, assurant une bonne protection contre la boue.
- NL Verbeterde, 'moddervriendelijke' kabelvoering langs de bovenbuis.

►► Three sets of water bottle bosses.

- DE Sockel für drei Flaschenhalter.
- ES Tres puntos de anclaje para portabidones.
- IT Tre predisposizioni per le borracce.
- FR Trois attaches porte-bidons.
- NL Drie bevestigingspunten voor bidonhouders.

►►► Larger diameter seat tube is stiffer, allowing all pedaling force to be transmitted to the wheel, not lost through side to side flexing.

- DE Steiferes Sitzrohr durch vergrößerten Durchmesser. Dadurch wird die Pedalkraft vollständig zum Hinterrad übertragen und geht nicht durch seitliches Ausweichen des Hinterbaus verloren.
- ES Grueso tubo vertical más rígido para lograr que toda la potencia del pedaleo se transmita a la rueda en lugar de flexionar lateralmente el cuadro.
- IT Il tubo sella a diametro più largo è più rigido per trasmettere tutta la potenza della pedalata alla ruota ed evitare che si disperda in flessibilità laterale.
- FR Tube de selle de plus grand diamètre plus rigide, pour transmettre toute la force de pédalage à la roue, sans perte par effet de flexion latérale.
- NL Vergrote diameter van de zitbuis zorgt voor meer stijfheid, waardoor alle aandrijfkraft via de pedalen naar het wiel gaat, en geen verlies door zijdelingse flex optreedt.

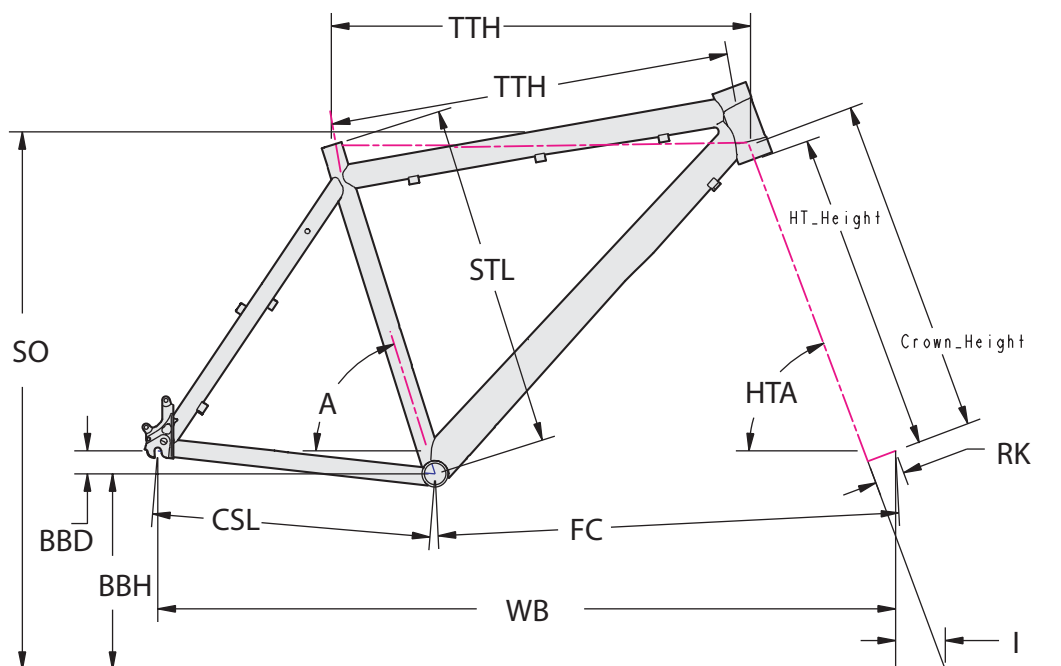

## FRAME SPECIFICATION

ITEM	SPECIFICATION
MODEL	CAFFEINE
Frame	6061-T6, Tig welded, Aluminum Alloy
Sizes	S, M, L, X
Seatpost Diameter	31.6mm
Headtube	Headshok, OnePointFive
Bottom Bracket	68mm, English threaded
Dropout Spacing	135mm
Hub Spacing	135mm
Front Derailleur	34.9mm clamp-on
Rear Brake Mount	International Standard, 6"

## GEOMETRY

ITEM	REF	SMALL	MEDIUM	LARGE	X-LARGE
Seat tube angle (degree)	STL	73.5	73.5	73	72.5
Head tube angle (degree)	HTA	70	70	70	70
Horizontal top tube (cm)	TTH	56.5	59.7	62.2	63.5
Horizontal top tube actual (cm)	TTA	53.1	56.1	58.9	60.9
Seat tube length (cm)	STL	38	43.3	47.5	52.5
Chainstay length (cm)	CSL	42.4	42.4	42.4	42.4
Bottom bracket height (cm)	BBH	29.8	29.8	29.8	29.8
Bottom bracket drop	BBD	3.5	3.5	3.5	3.5
Wheelbase (cm)	WB	104.9	108.2	110.6	111.7
Stand over height (cm)	SO	76.4	77.7	79.7	82
Front-center distance (cm)	FC	62.8	66.1	68.5	69.5
Head tube length (cm)	HTL	11.8	11.8	11.8	11.8
Head tube height (cm)	HTH	49	49	49	49
Fork rake (cm)	RK	4.5	4.5	4.5	4.5
Trail (cm)	TR	7.3	7.3	7.3	7.3



## CAFFEINE 2



Ball Burnished (gloss) (BBS)

Frame	△	Caffeine
Fork	∩	Lefty Speed 110 DLR2
Rear Shock	⊞	N/A
Rims	○	Mavic XM317 Disc, 32 hole
Hubs	⊕	Cannondale Lefty front, DT Swiss XC rear
Spokes	✱	DT Swiss Champion
Tires	⊞	Hutchinson Piranha, 26 x 2.0"
Pedals	⊞	crankbrothers candy c
Crank	⊕	FSA V-drive MegaExo, 22/32/44
Bottom Bracket	⊞	FSA MegaExo
Chain	○	Shimano HG-53
Rear Cogs	≡	SRAM PG-950, 11-34
Front Derailleur	⤴	Shimano LX
Rear Derailleur	⤵	Shimano XT
Shifters	⊕	Shimano LX RAPIDFIRE plus
Handlebar	∩	FSA XC-282-AOS, 25mm rise
Stem	⊞	Cannondale XC3 Headshok 31.8mm
Headset	⊕	Cannondale Headshok Si
Brakes	⊞	Shimano LX w/ 160mm rotors
Brake Levers	∩	Shimano LX
Saddle	∩	Cannondale XC
Seatpost	∩	FSA SP-FR-270, 31.6 x 350mm
Sizes	⊞	S,M,L,X
Color Code	⊞	Berserker Green w/ NRG Yellow (Gloss) (NEO) Ball Burnished (gloss) (BBS)
Extra's	...!	Cannondale V-Tech grips

Notes:



CAFFEINE 3

Frame	▽	Caffeine
Fork	┌	HeadShok Super Fatty Ultra 80 DLR
Rear Shock	⊞	N/A
Rims	○	Mavic XM117 Disc, 32 hole
Hubs	⊞	Formula DC-94 front, DC-58 rear
Spokes	✱	DT Swiss Champion
Tires	▨	Hutchinson Piranha, 26 x 2.0"
Pedals	⊞	Welgo Clipless
Crank	⊞	FSA V-drive MegaExo, 22/32/44
Bottom Bracket	⊞	FSA MegaExo
Chain	○	Shimano HG-53
Rear Cogs	≡	SRAM PG-950, 11-34
Front Derailleur	≡	Shimano LX
Rear Derailleur	≡	SRAM X-9
Shifters	⊞	SRAM X-7 Trigger
Handlebar	┌	FSA XC-282-AOS, 25mm rise
Stem	┌	Cannondale XC3 Headshok 31.8mm
Headset	⊞	Cannondale Headshok Si
Brakes	⊞	Avid Juicy 5 w/ 160mm rotors
Brake Levers	┌	Avid Juicy 5
Saddle	┌	Cannondale XC
Seatpost	┌	FSA SP-FR-270, 31.6 x 350mm
Sizes	≡	S,M,L,X
Color Code	┌	Tangerine (gloss) (ORG) Charcoal Grey (matte) (GRY)
Extra's	...!	Cannondale V-Tech grips
Notes:		



Charcoal Grey (matte) (GRY)



## CAFFEINE 4



Patriot Blue (gloss) (BLU)

Frame	∇	Caffeine
Fork	∩	HeadShok Super Fatty Ultra 80 DLR
Rear Shock	⊞	N/A
Rims	○	Mavic XM117 Disc, 32 hole
Hubs	⊞	Shimano M475
Spokes	✱	DT Swiss Champion
Tires	⊞	Hutchinson Spider, 26 x 2.0"
Pedals	⊞	Welgo Clipless
Crank	⊞	FSA Alpha Drive, 22/32/44
Bottom Bracket	⊞	FSA ISIS SL
Chain	○	Shimano HG-53
Rear Cogs	⊞	SRAM PG-950, 11-34
Front Derailleur	⊞	Shimano LX
Rear Derailleur	⊞	Shimano XT
Shifters	⊞	Shimano Deore RAPIDFIRE plus
Handlebar	∩	Cannondale C3, 20mm rise
Stem	⊞	Cannondale XC3 Headshok 31.8mm
Headset	⊞	Cannondale Headshok Si
Brakes	⊞	Avid Juicy 3 w/ 160mm rotors
Brake Levers	∩	Avid Juicy 3
Saddle	∩	Cannondale XC
Seatpost	∩	FSA SP-FR-270, 31.6 x 350mm
Sizes	⊞	S,M,L,X
Color Code	∩	Patriot Blue (gloss) (BLU) Fine Silver (gloss) (SLV)
Extra's	...!	Cannondale V-Tech grips

Notes:

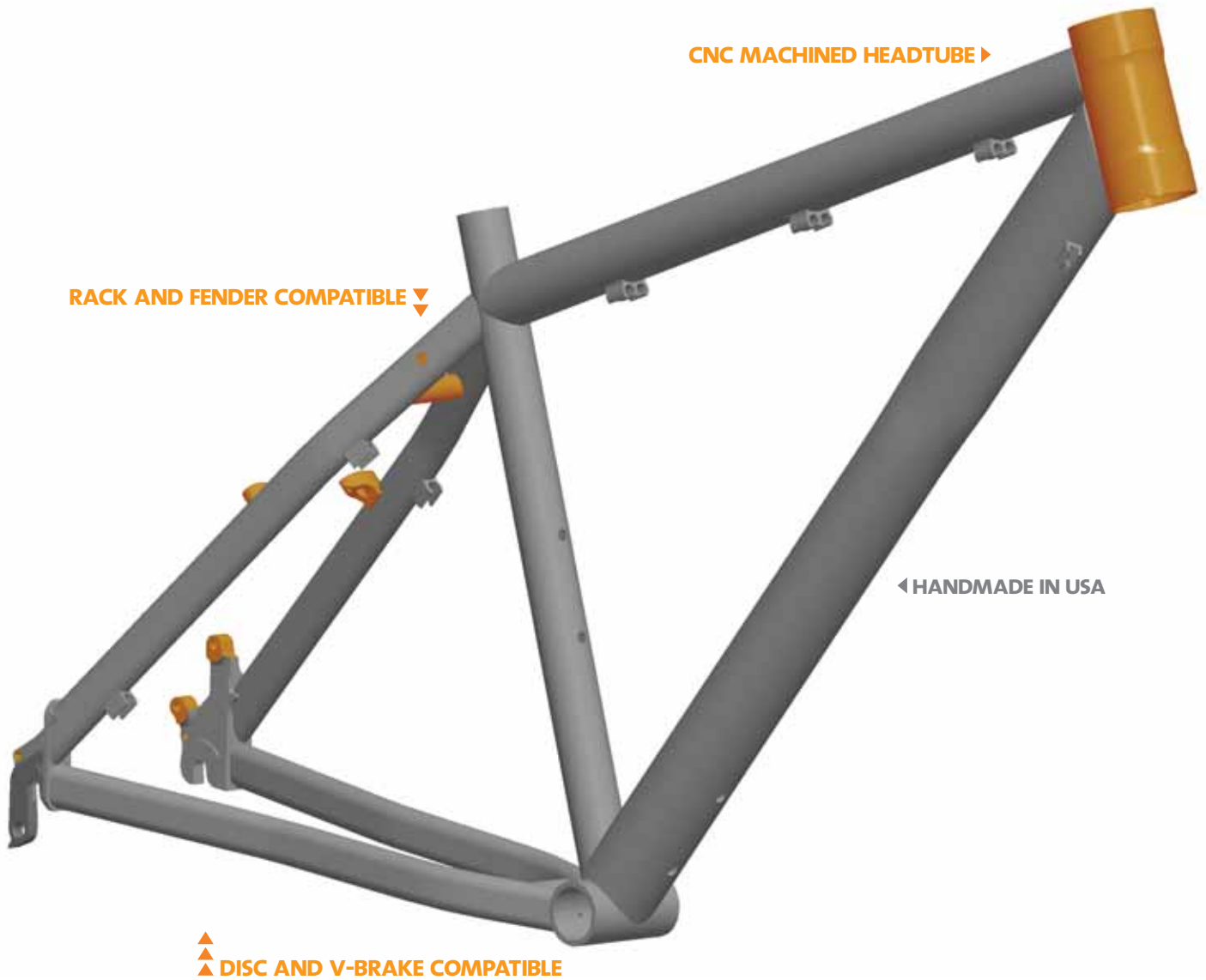

## FURIO-X

### ► CNC machined, externally butted headtube.

- DE CNC-bearbeitetes, außen konifiziertes Steuerrohr.
- ES Pipa con rebaje mecanizado externo.
- IT Tubo sterzo a spessore esterno differenziato, lavorato a macchina CNC.
- FR Tube de direction à épaisseur variable usiné par machine à commande numérique.
- NL CNC-gefreesde, extern geconificeerde vorkbuis.

### ►► Rack and fender compatible.

- DE Montagemöglichkeit für Schutzblech und Gepäckträger.
- ES Compatible con guardabarros y portaequipajes.
- IT Predisposizioni per portapacchi e parafanghi.
- FR Peut recevoir porte-bagages et garde-boue.
- NL Geschikt voor bagagedragers en spatborden.

### ►►► Furio X frameset is disc and V-brake compatible.

- DE Der Furio X-Rahmen ist Scheibenbrems- und V-Brake-kompatibel.
- ES El cuadro Furio X es compatible con frenos V-brake y de disco.
- IT Il telaio Furio X accoglie freni a disco e V-brake.
- FR La cadre du Furio X est compatible avec les freins à disque et V-brake.
- NL Furio X frameset is geschikt voor schijfremmen en V-brakes.

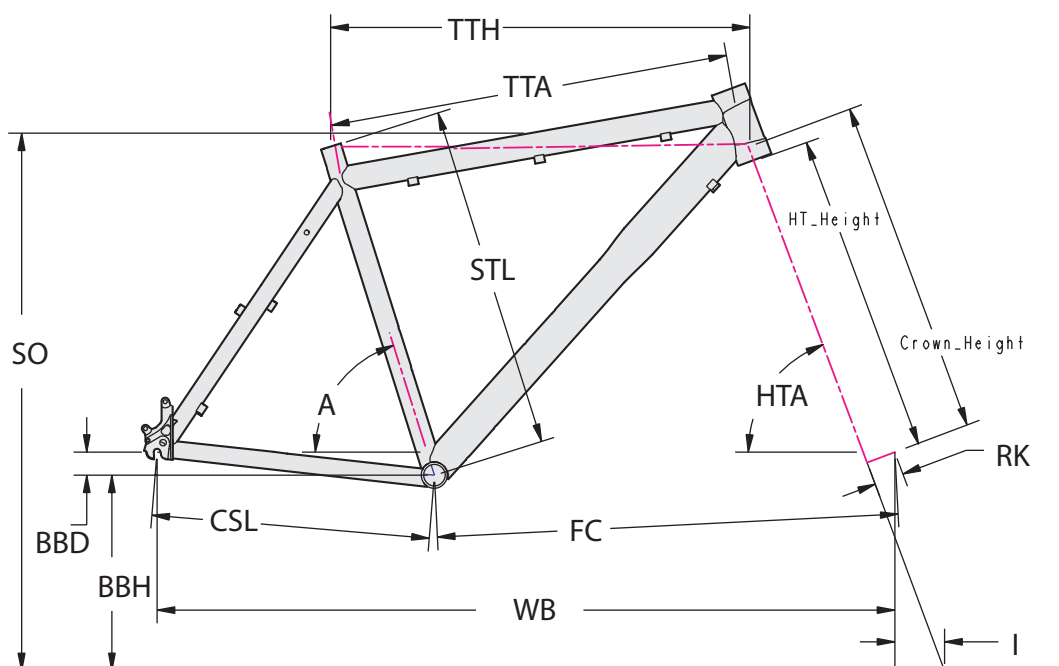

## FRAME SPECIFICATION

ITEM	SPECIFICATION
MODEL	FURIO-X
Frame material	6061 T6, TIG Welded Aluminum Alloy
Sizes	S, M, L, X
Seatpost diameter	31.6mm
Headset	Headshok, OnePointFive
Bottom bracket	English threaded, 68mm
Dropout spacing	135mm
Hub spacing	135mm
Front derailleur	34.9mm clamp-on
Rear brake mount	International standard, 6"/ V-brake compatible

## GEOMETRY

ITEM	REF	PETITE	SMALL	MEDIUM	LARGE	X-LARGE
Seat tube angle (degree)	STL	75	73.5	73.5	73	72.5
Head tube angle (degree)	HTA	70	70	70	70	70
Horizontal top tube (cm)	TTH	54.4	56.5	59.7	62.2	63.5
Seat tube length (cm)	STL	33	38	43.2	41.5	52.5
Chainstay length (cm)	CSL	42.4	42.4	42.4	42.4	42.4
Bottom bracket height (cm)	BBH	29.8	29.8	29.8	29.8	29.8
Bottom bracket drop	BBD	3.5	3.5	3.5	3.5	3.5
Wheelbase (cm)	WB	103.4	104.9	108.2	110.6	111.8
Stand over height (cm)	SO	72.8	75.2	71.6	79.6	81.9
Front-center distance (cm)	FC	61.3	62.8	66.3	68.6	69.7
Fork rake (cm)	RK	4.5	4.5	4.5	4.5	4.5
Trail (cm)	TR	7.3	7.3	7.3	7.3	7.3



FURIO-X 5

Frame		Furio-X
Fork		HeadShok Super Fatty Ultra 80 DL
Rear Shock		N/A
Rims		Mach 1 XC 2.10, 32 hole
Hubs		Shimano M475
Spokes		DT Swiss Champion
Tires		Hutchinson Spider, 26 x 2.0"
Pedals		Wellgo alloy cage w/ clip and strap
Crank		Truvativ IsoFlow, 22/32/44
Bottom Bracket		Shimano BB-UN26
Chain		Shimano HG-53
Rear Cogs		SRAM PG-950, 11-34
Front Derailleur		Shimano Deore
Rear Derailleur		SRAM X-7
Shifters		SRAM SX-5 Trigger
Handlebar		Cannondale C3, 20mm rise
Stem		Cannondale XC3 Headshok 31.8mm
Headset		Cannondale Headshok Si
Brakes		Cannondale Fire
Brake Levers		Cannondale Earth
Saddle		Cannondale XC
Seatpost		Cannondale C4, 27.2 x 350mm
Sizes		S,M,L,X
Color Code		Lightning White (gloss) (WHT) Teak Brown (gloss) (BRN)
Extra's		Cannondale V-Tech grips
Notes:		



Lightning White (gloss) (WHT)



## FURIO-X 6



Jet Black (matte) (BBQ)

Frame	▽	Furio-X
Fork	┆	RockShox Dart 2 TurnKey LO 80mm
Rear Shock	▭	N/A
Rims	○	Mach 1 XC 2.10, 32 hole
Hubs	┆	Cannondale Earth
Spokes	✱	DT Swiss Champion
Tires	⋯	Hutchinson Spider, 26 x 2.0"
Pedals	▭	Wellgo alloy cage w/ clip and strap
Crank	⊕	Truvativ IsoFlow, 22/32/44
Bottom Bracket	┆	Shimano BB-UN26
Chain	○	SRAM PC-38
Rear Cogs	▸	Sunrace M60, 11-32
Front Derailleur	┆	Shimano Alivio
Rear Derailleur	⋈	SRAM SX-5
Shifters	⊕	SRAM SX-4 Trigger
Handlebar	┆	Cannondale C3, 20mm rise
Stem	┆	Cannondale XC3 Headshok 31.8mm
Headset	⊕	FSA Orbit DL 1-1/8"
Brakes	┆	Cannondale Fire
Brake Levers	┆	Cannondale Earth
Saddle	┆	VELO 1061 XC
Seatpost	┆	Cannondale C4, 27.2 x 350mm
Sizes	┆	S,M,L,X
Color Code	┆	Race Red (gloss) (RED) Jet Black (matte) (BBQ)
Extra's	...!	Cannondale V-Tech grips

Notes: