



RUSH

Caffeine.

FEMININE

FEMININE

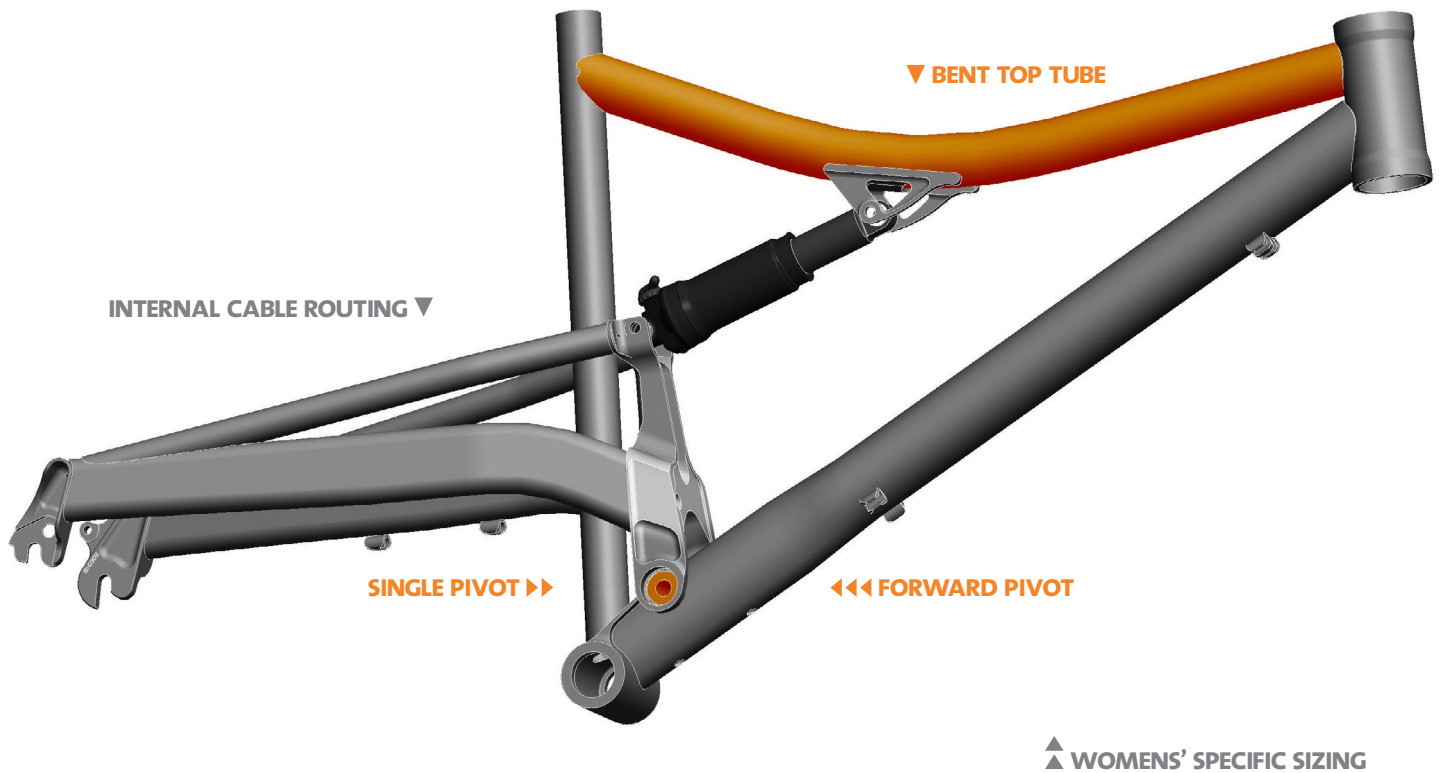

RUSH FEMININE

▶▶ Top tube bend provides extra stand over clearance.

- DE Die Biegung im Oberrohr ermöglicht eine besonders große Schrittfreiheit.
- ES Tubo curvo para incrementar la distancia hasta la entrepierna.
- IT La piegatura del tubo orizzontale assicura maggior spazio al cavallo.
- FR La courbure du tube horizontal apporte un dégagement confortable au niveau de l'entrejambe.
- NL Gebogen bovenbuis zorgt voor meer beenvrijheid.

▶ Single pivot for efficiency, low weight and ease of maintenance.

- DE Niedriges Gewicht und geringer Wartungsaufwand durch Eingelenkskonstruktion.
- ES Pivote único para lograr una mayor eficacia, un menor peso y un sencillo mantenimiento.
- IT Fulcro singolo per efficienza, riduzione del peso e facile manutenzione.
- FR Système à pivot unique, pour gagner en efficacité, en poids et en facilité d'entretien.
- NL Enkel draaipunt voor rendement, laag gewicht en eenvoudig onderhoud.

▶▶▶ Forward pivot achieves the optimum balance between bump response and pedaling efficiency.

- DE Der vorgelagerte Drehpunkte bietet eine optimale Balance zwischen Dämpfungseigenschaften und Effektivität beim Treten.
- ES El pivote adelantado prove un optimo equilibrio entre respuesta a los impactos y eficiencia de pedaleo.
- IT La posizione avanzata del fulcro ottimizza l'equilibrio tra risposta agli impatti ed efficienza della pedalata.
- FR Le pivot placé en avant offre un équilibre parfait entre efficacité et rendement.
- NL Doordat het draaipunt voor het trapashuis is geplaatst wordt een optimale balans bereikt tussen schok absorptie en pedaal efficiëntie

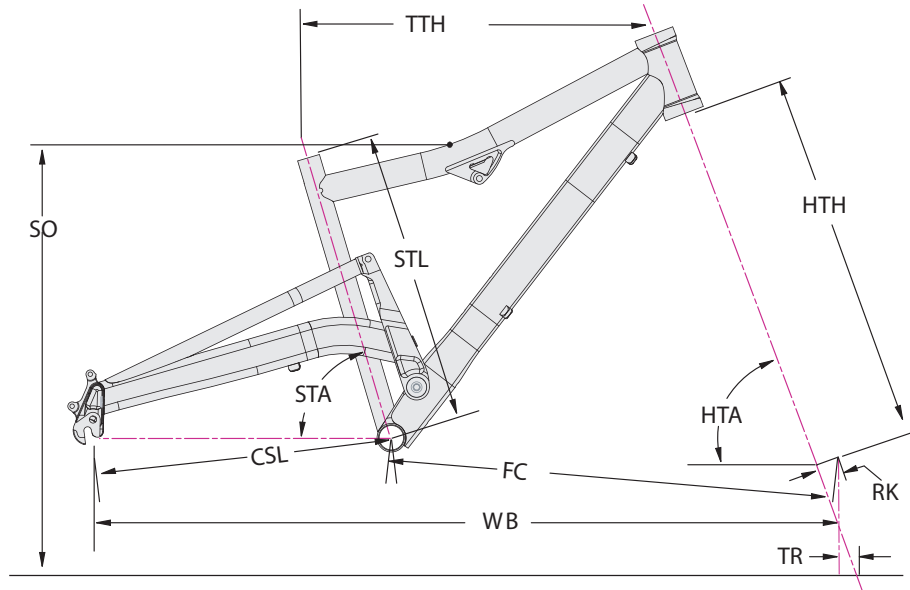

FRAME SPECIFICATION

GEOMETRY

ITEM	SPECIFICATION
MODEL	RUSH FEMININE
Frame material	6061-t6, tig welded, aluminum alloy
Sizes	P, S, M
Maximum tire width	2.3"
Head tube	Headshok, OnePointFive
Maximum fork length	500mm
Seat post diameter	27.2 ±0.1mm
Rear shock bushing width (frame mount)	32.4 ±0.1mm
Rear shock bushing width (swingarm)	37.4 ±0.1mm
Bolt diameter	8.1 ±0.5mm
Rear shock eyelet-to-eyelet length	190 mm (7.5")
Rear wheel travel	110mm
Rear shock stroke length	45mm
Rear shock leverage ratio	3:1 regressive
Front derailleur	Bottom pull top swing 31.8mm
Bottom bracket shell (width, thread type)	68mm, English
Chain line	47.5mm
Dropout spacing	135mm
Rear hub spacing	135mm
Rear axle	Quick release
Rear brake mount	International standard, 6"

ITEM	REF	PETITE	SMALL	MEDIUM
Seat tube angle (degree)	STA	73.5°	73.5°	73.5°
Head tube angle (degree)	HTA	69°	69°	69°
Horizontal top tube (cm)	TTH	54.5	57.55	58.7
Seat tube length (cm)	STL	40.5	40.5	41.5
Chainstay length (cm)	CSL	42.2	42.2	42.2
Bottom bracket height (cm)	BBH	32	32	32
Wheelbase (cm)	WB	104.5	107.5	108.8
Trail (cm)	TR	5.8	5.8	5.8
Stand over height (cm)	SO	74.6	75.4	75.4
Bottom bracket drop (cm)	BBD	1	1	1
Front-center distance (cm)	FC	63.5	66.5	66.6
Fork rake (cm)	RK	4.6	4.6	4.6
Rear travel (cm)		12	12	12
Shock eye-to-eye (cm)		19	19	19
Shock stroke (cm)		4.45	4.45	4.45
Recommended sag (%)		.25	.25	.25

* All dimensions: suspension fully extended.

FEMININE



RUSH FEMININE 1

Frame	▽	Rush Feminine 110mm
Fork	┆	Lefty Speed 110 DLR2
Rear Shock	▢	Fox Float RPL Air
Rims	○	Mavic XM819 Disc UST, 24 hole
Hubs	▬	Cannondale Lefty front, DT Swiss XC rear
Spokes	✱	DT Swiss Competition
Tires	⋯	Maxxis CrossMark UST, 26 x 2.1"
Pedals	▣	crankbrothers candy c
Crank	⊕	FSA Afterburner MegaExo, 22/32/44
Bottom Bracket	▬	FSA MegaExo
Chain	○	SRAM 951
Rear Cogs	≡	SRAM PG-970, 11-34
Front Derailleur	≡	Shimano LX
Rear Derailleur	≡	SRAM X-9
Shifters	⊕	SRAM X-7 Trigger
Handlebar	┆	FSA XC-281-AOS, Women Specific
Stem	┆	Cannondale XC3 Headshok 31.8mm
Headset	⊕	Cannondale Headshok Si
Brakes	≡	Avid Juicy 7 w/ 160mm rotors
Brake Levers	┆	Avid Juicy 7
Saddle	┆	Terry Butterfly
Seatpost	┆	Cannondale Fire, 27.2 x 350mm
Sizes	▬	P,S,M
Color Code	┆	Lightning White (gloss) (WHT)
Extra's	⋯	Cannondale V-Tech grips
Notes:		



RUSH FEMININE 2

Frame	△	Rush Feminine 110mm
Fork	∩	Lefty Speed 110 DLR2
Rear Shock	⊞	Fox Float RP2 Air
Rims	○	Mavic XM117 Disc, 32 hole
Hubs	⊞	Cannondale Lefty front, Shimano M475 rear
Spokes	✱	DT Swiss Champion
Tires	⊞	Hutchinson Spider, 26 x 2.0"
Pedals	⊞	Wellgo alloy cage w/ clip and strap
Crank	⊞	FSA Alpha Drive, 22/32/44
Bottom Bracket	⊞	FSA ISIS SL
Chain	○	Shimano HG-53
Rear Cogs	≡	SRAM PG-950, 11-34
Front Derailleur	≡	Shimano LX
Rear Derailleur	≡	Shimano XT
Shifters	⊞	Shimano Deore RAPIDFIRE plus
Handlebar	∩	FSA XC-281-AOS, Women Specific
Stem	∩	Cannondale XC3 Headshok 31.8mm
Headset	⊞	Cannondale Headshok Si
Brakes	⊞	Avid Juicy 3 w/ 160mm rotors
Brake Levers	∩	Avid Juicy 3
Saddle	∩	Terry Butterfly
Seatpost	∩	FSA SP-FR-270, 27.2 x 350mm
Sizes	≡	P,S,M
Color Code	∩	Fine Silver (gloss) (SLV)
Extra's	...!	Cannondale V-Tech grips
Notes:		

FEMININE

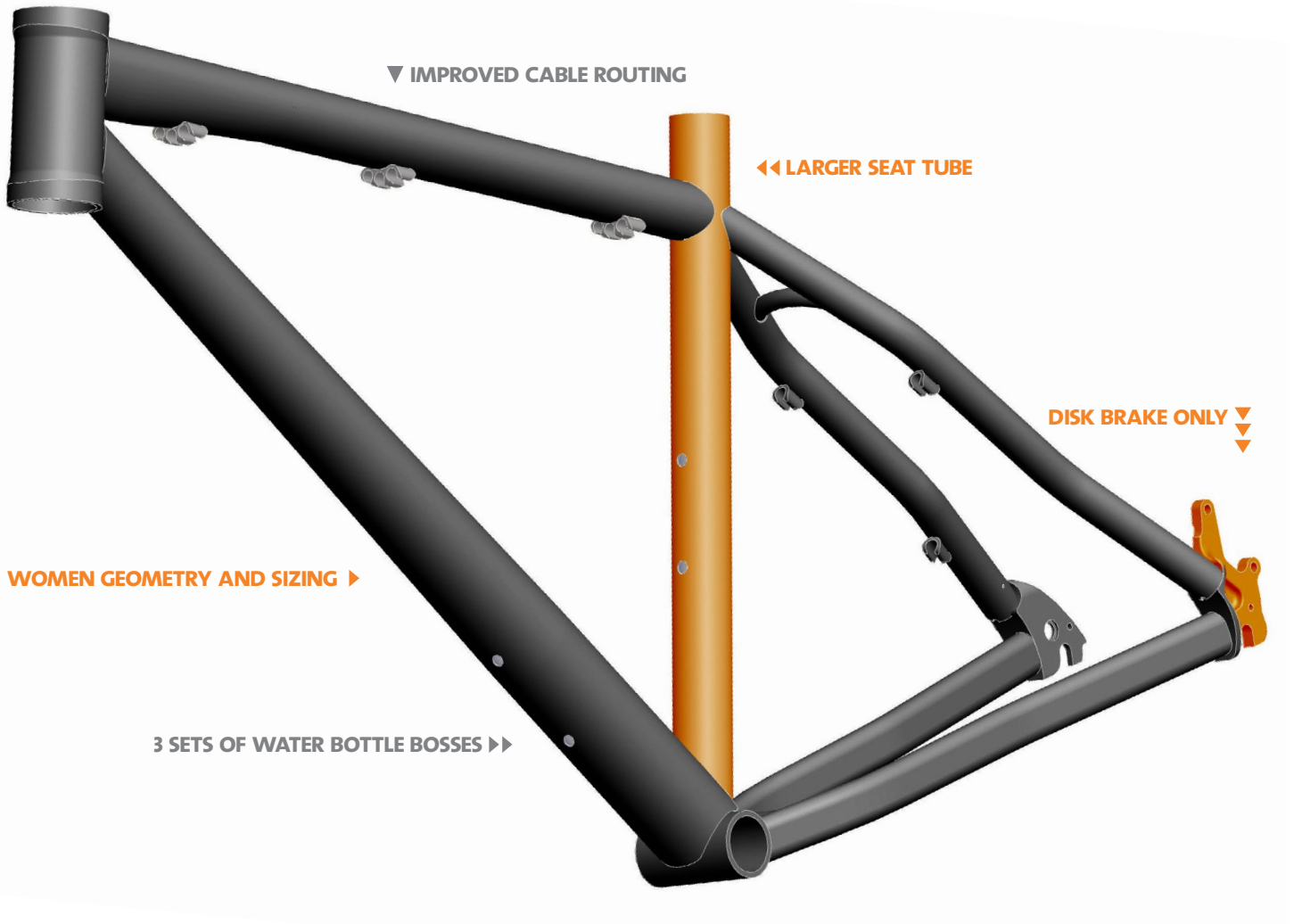

CAFFEINE FEMININE

▶ Appropriate geometry and sizing for Women's fit needs.

- DE Geometrie und Größen sind auf die Bedürfnisse weiblicher Fahrer exakt abgestimmt.
- ES Geometría y tallas adaptadas a las proporciones femeninas.
- IT Misure e geometria attente alle esigenze femminili.
- FR Caractéristiques de géométrie et de taille spécialement conçues pour les femmes.
- NL Geometrie en maatvoering aangepast aan de wensen van vrouwen.

▶▶▶ Larger diameter seat tube is stiffer, allowing all pedaling force to be transmitted to the wheel, not lost through side to side flexing.

- DE Steiferes Sitzrohr durch vergrößerten Durchmesser. Dadurch wird die Pedalkraft vollständig zum Hinterrad übertragen und geht nicht durch seitliches Ausweichen des Hinterbaus verloren.
- ES Grueso tubo vertical más rígido para lograr que toda la potencia del pedaleo se transmita a la rueda en lugar de flexionar lateralmente el cuadro.
- IT Il tubo sella a diametro più largo è più rigido per trasmettere tutta la potenza della pedalata alla ruota ed evitare che si disperda in flessibilità laterale.
- FR Tube de selle de plus grand diamètre, plus rigide, pour transmettre toute la force de pédalage à la roue, sans perte par effet de flexion latérale.
- NL Vergrote diameter van de zitbuis zorgt voor meer stijfheid, waardoor alle aandrijfkraft via de pedalen naar het wiel gaat.

▶▶ Disc brake only.

- DE Nur Scheibenbremsen-kompatibel.
- ES Compatible sólo con freno a disco.
- IT Solo freni a disco.
- FR Freins à disque uniquement.
- NL Alleen geschikt voor schijfremmen.

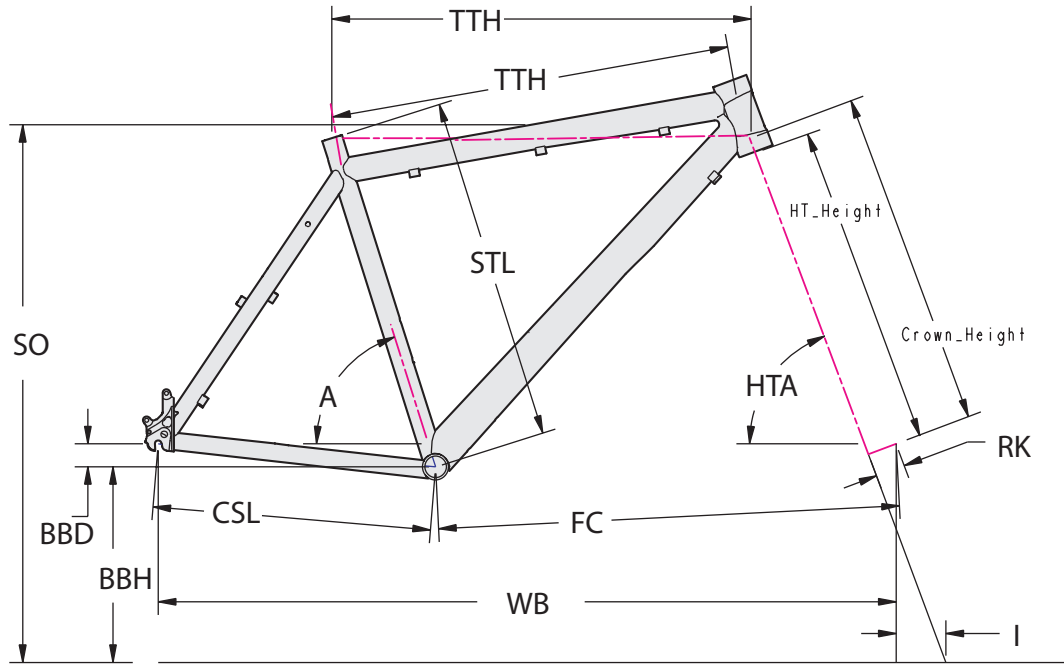

FRAME SPECIFICATION

GEOMETRY

ITEM	SPECIFICATION
MODEL	CAFFEINE FEMININE
Frame	6061-T6, Tig welded, Aluminum Alloy
Sizes	P, S, M
Seatpost Diameter	31.6mm
Headtube	Headshok, OnePointFive
Bottom Bracket	68mm, English threaded
Dropout Spacing	135mm
Hub Spacing	135mm
Front Derailleur	34.9mm clamp-on
Rear Brake Mount	International Standard, 6"

ITEM	REF	PETITE	SMALL	MEDIUM
Seat tube angle (degree)	STL	75	73.5	73.5
Head tube angle (degree)	HTA	70	-	-
Horizontal top tube (cm)	TTH	54.4	56.5	58.4
Horizontal top tube actual (cm)	TTA	51.8	53.1	54.9
Seat tube length (cm)	STL	35	38	40
Chainstay length (cm)	CSL	42.5	-	-
Bottom bracket height (cm)	BBH	29.8	-	-
Bottom bracket drop	BBD	3.5	-	-
Wheelbase (cm)	WB	103.3	104.9	107
Stand over height (cm)	SO	73.5	76.4	78.2
Front-center distance (cm)	FC	61.2	62.8	64.9
Head tube length (cm)	HTL	11.8	-	-
Head tube height (cm)	HTH	49	-	-
Fork rake (cm)	RK	4.5	-	-
Trail (cm)	TR	7.3	-	-

FEMININE



CAFFEINE FEMININE

Frame	△	Caffeine Feminine
Fork	∩	Super Fatty Ultra 80 DL
Rear Shock	⊞	N/A
Rims	○	Mavic XM117 Disc, 32 hole
Hubs	⊞	Shimano M475
Spokes	✱	DT Swiss Champion
Tires	⊞	Hutchinson Spider, 26 x 2.0"
Pedals	⊞	Wellgo alloy cage w/ clip and strap
Crank	⊞	Truvativ IsoFlow, 22/32/44
Bottom Bracket	⊞	Shimano BB-UN26
Chain	○	Shimano HG-53
Rear Cogs	≡	SRAM PG-950, 11-34
Front Derailleur	≡	Shimano Deore
Rear Derailleur	≡	SRAM X-7
Shifters	⊞	SRAM SX-5 Trigger
Handlebar	∩	Cannondale C3, 20mm rise
Stem	⊞	Cannondale XC3 Headshok 31.8mm
Headset	⊞	Cannondale Headshok Si
Brakes	⊞	Avid Juicy 3 w/ 160mm rotors
Brake Levers	∩	Avid Juicy 3
Saddle	∩	Terry Cite
Seatpost	∩	Cannondale C4, 31.6 x 350mm
Sizes	≡	P,S,M
Color Code	⊞	Pink (gloss) (PNK)
Extra's	⋮	Cannondale V-Tech grips
Notes:		



SYNAPSE

FEMININE

FEMININE GEOMETRY AND SIZING ▶

TRIAxIAL HOURGLASS SEATSTAYS ▶

50MM OF RAKE ▶▶

◀◀ SI BOTTOM BRACKET

▲▲ SAVE TECHNOLOGY

SYNAPSE FEMININE

▶ Appropriate geometry and sizing for Women's fit needs.

- DE Geometrie und Größen sind auf die Bedürfnisse weiblicher Fahrer exakt abgestimmt.
- ES Geometría y tallas adaptadas a las proporciones femeninas.
- IT Misure e geometria attente alle esigenze femminili.
- FR Caractéristiques de géométrie et de taille spécialement conçues pour les femmes.
- NL Geometrie en maatvoering aangepast aan de wensen van vrouwen.

▶▶ Synapse feminine fork has 50mm of rake for more forgiving steering.

- DE Die Synapse-Feminine-Gabel hat eine Vorbiegung von 50 mm und ist dadurch fehlerverzeihender entspannter zu fahren.
- ES Conducción más estable gracias a los 50 mm de avance de la horquilla del modelo Feminine.
- IT La forcella della Synapse Feminine ha 50mm di avancorsa per uno sterzo più indulgente.
- FR La fourche du Synapse féminine bénéficie d'un déport de 50 mm, pour un contrôle de la direction plus aisé.
- NL Synapse feminine voorvork heeft 50mm vorksprong voor een rustiger stuurgedrag.

▶▶▶ SAVE technology seat stays create enough flex to dampen road vibrations without sapping power.

- DE Die in SAVE-Technologie konzipierten Sitzstreben dämpfen durch ihre Flexibilität, die von rauen Straßenbelag verursachten Vibrationen, ohne dabei Tretkraft zu verschwenden.
- ES Los tirantes con tecnología SAVE permiten el grado de compresión vertical justo para amortiguar las vibraciones sin restar potencia.
- IT I tubi verticali posteriori con tecnologia SAVE creano la flessibilità necessaria a smorzare le vibrazioni della strada senza sottrarre potenza.
- FR Grâce à leur flexibilité, les haubans "SAVE" permettent d'absorber les vibrations de la route sans perte d'efficacité de pédalage.
- NL SAVE-technologie staande achtervorken geven precies voldoende flexibiliteit om trillingen te dempen zonder verlies van aandrijfkraft.

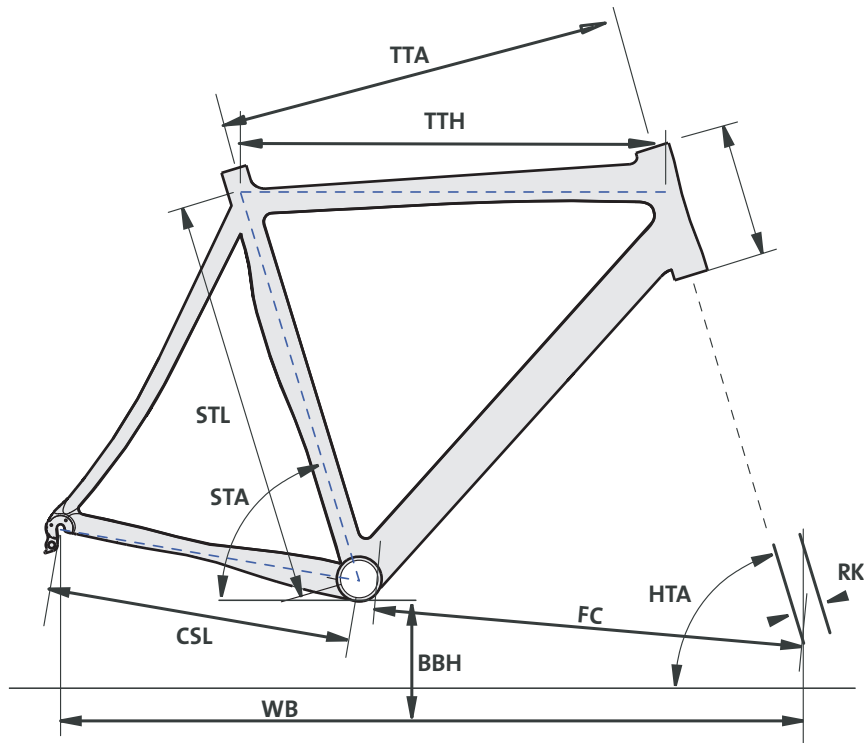

FRAME SPECIFICATION

GEOMETRY

ITEM	SPECIFICATION
MODEL	SYNAPSE Carbon Feminine and Synapse Feminine
Frame material	Carbon Fiber & 6061 T6, TIG Welded Aluminum Alloy
Sizes	47, 50, 53, 56
Seatpost diameter	31.6 mm & 27.2mm
Headset	Integrated
Bottom bracket	Cannondale Si & English threaded, 68mm
Front dropout spacing	100mm
Rear dropout spacing	130mm
Front derailleur	34.9mm clamp-on
Stem/fork	1 1/8" diameter

ITEM	REF	47	50	53	56
Seat tube angle (degree)	STL	75	74.5	74	7.5
Head tube angle (degree)	HTA	71	72	72.5	73
Horizontal top tube (cm)	TTH	51.5	53	54.5	56
Seat tube length (cm)*	STL	44	47	50	53
Chainstay length (cm)	CSL	41	41	41	41
Bottom bracket height (cm)	BBH	26.5	26.5	26.5	26.8
Bottom bracket drop	BBD	7.2	7.2	7.2	6.9
Wheelbase (cm)	WB	97.4	97.9	98.7	99.5
Stand over height (cm)	SO	72.5	74.5	76.9	79.5
Front-center distance (cm)	FC	57.5	58	58.8	59.5
Head tube length (cm)	HTL	11	12	14	16
Fork rake (cm)	RK	5.0	5.0	5.0	5.0

* The measured size is from the center of the bottom bracket to the top of the top tube along the seat tube axis.

FEMININE



SYNAPSE CARBON FEMININE SI 105 COMPACT DRIVE

Frame	△	Synapse Carbon Feminine Si BB
Fork	∩	Cannondale Synapse Carbon
Rims	○	Mavic Aksium Race
Hubs	⊕	Mavic Aksium Race
Spokes	✱	Mavic Aksium Race
Tires	⊞	Hutchinson Top Speed Kevlar 700x23c
Pedals	⊞	N/A
Crank	⊕	Shimano FC-R 600 34/50
Bottom Bracket	⊕	Shimano FC-R 600
Chain	○	Shimano 105 10 speed
Rear Cogs	≡	Shimano 105 10 speed 12-27
Front Derailleur	↗	Shimano 105 10 speed
Rear Derailleur	↘	Shimano 105 10 speed
Shifters	⊕	Shimano ST-R700
Handlebar	∩	ITM Elle
Stem	∩	Cannondale C3 31.8mm
Headset	⊕	FSA Orbit Si
Brakes	⊕	Shimano 105 10 speed
Brake Levers	∩	Shimano ST-R700
Saddle	∩	Fi'zi:k Vitesse CP Feminine
Seatpost	∩	FSA SL-K Carbon 31.6x300mm
Sizes	≡	47,50,53,56
Color Code	∩	Lightning White (gloss) (WHT)
Extra's	⋮	N/A
Notes:		



SYNAPSE FEMININE TRIPLE

Frame	△	Synapse Feminine
Fork	∩	Cannondale Synapse Carbon
Rims	○	Mavic CXP225 32h
Hubs	⊕	Cannondale Earth
Spokes	✱	DT Swiss Champion 2.0
Tires	⊞	Maxxis Fuse 700x25c
Pedals	⊞	N/A
Crank	⊕	Truvativ Touro S3T Triple 30/42/52
Bottom Bracket	∩	Shimano BB-UN26
Chain	○	Shimano HG53
Rear Cogs	≡	SRAM PG-950 12-26
Front Derailleur	↗	Shimano 105 9 speed
Rear Derailleur	↘	Shimano 105 9 speed
Shifters	⊕	Shimano ST-R600
Handlebar	∩	ITM Elle
Stem	∩	Cannondale C4 31.8mm
Headset	⊕	FSA Orbit Si
Brakes	∩	Cannondale Delta
Brake Levers	↗	Shimano ST-R600
Saddle	∩	Fi'zi:k Vitesse Sport Feminine
Seatpost	∩	Cannondale C4 27.2x250mm
Sizes	≡	47,50,53,56
Color Code	∩	Mediterranean Blue (gloss) (BLU)
Extra's	...!	N/A
Notes:		